

Connections

*This chapter gives instructions on connecting your **CDQPrima** to the network, your audio equipment and your remote control systems*

3. CDQPrima Connections

3.1 Connections to the Network

The **CDQPrima** may be equipped with a variety of digital interface modules for ISDN, leased circuits, and other transmission media (including V.35 and X.21/RS422 protocols). In addition, since the RS422 interface is electrically compatible with industry standard RS449 equipment, the **CDQPrima** X.21/RS422 adapter can be used with RS449 equipment with the addition of an adapter cable. Each of these digital interfaces requires clock and data to be exchanged between the **CDQPrima** and the terminal equipment. The **CDQPrima** always expects the clock to be provided by the terminal equipment; therefore, only terminal equipment that provides clock data can be used. The encoder section outputs data synchronized with the clock and the decoder expects the data to be synchronized with the clock. Figures 3-1 and 3-2 show the interconnection of the **CDQPrima** with a generic piece of terminal equipment. The timing relationships are shown in the [CDQPrima Technical Reference Manual](#).

The data and clock lines are differential, and require a pair of wires for each signal. The control lines in the V.35 interface are single-ended and require only one wire for each signal. The X.21 control lines are differential. The RS422 interface does not support any control lines. Any RS422 input control lines defined are ignored by the **CDQPrima** and any output control lines defined are held at constant values. Refer to the

CDQPrima Technical Reference Manual for the definition of the pins used for each type of interface.

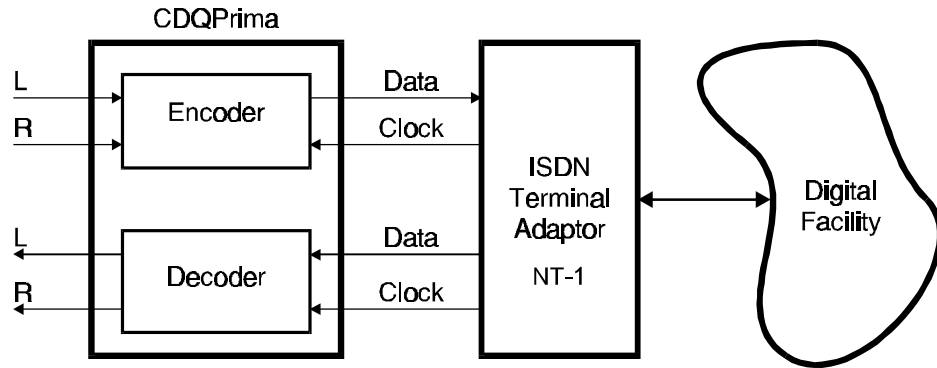

Figure 3-1 Basic Interconnection to Digital Network - RS422/V.35

3.1.1 V.35 Using the DIF102 Digital Interface Module

Each interface defines a voltage level for each of the signals. In the case of V.35 and X.21, a connector type is also defined. The large, rectangular connector defined in the V.35 specification is not used by the ***CDQPrima*** because of its size. Instead, a smaller DB15 connector is used. In the case of the V.35 interface, the ***CDQPrima*** conforms to the electrical specification but requires an adapter cable to convert the DB15 connector to the connector specified in the V.35 specification. The connector and the pin-out chosen for the V.35 interface in the ***CDQPrima*** are a common deviant found in many systems. An adapter cable is available, or can be made following the diagram found in the ***CDQPrima*** Technical Reference Manual. It is important to remember that V.35 has a separate clock for transmitted and received data.

3.1.2 X.21, RS422/RS449 Using the DIF101 Digital Interface Module

The RS422 interface specification defines only the electrical voltages at the interface and leaves the pin-out and meaning of the pins to the hardware designer. The RS449 interface specification utilizes the electrical specifications of RS422 but specifies a mechanical connector. RS449 equipment is therefore electrically compatible with the ***CDQPrima*** RS422 interface when an adapter cable is used. RS449 also specifies numerous control signals besides clock and data, which are not used by the ***CDQPrima***. The ***CDQPrima*** RS422 interface pin-out is specified in the ***CDQPrima*** Technical Reference Manual.

The RS422 interface also has a separate clock for the transmitted and received data. The RS422 interface can also echo the transmitter clock. If the terminal equipment clocks the encoder data with the echoed clock, then the **CDQPrima** may be located up to 4000 feet (1219 meters) from the terminal equipment without concern for the encoder-to-clock skew.

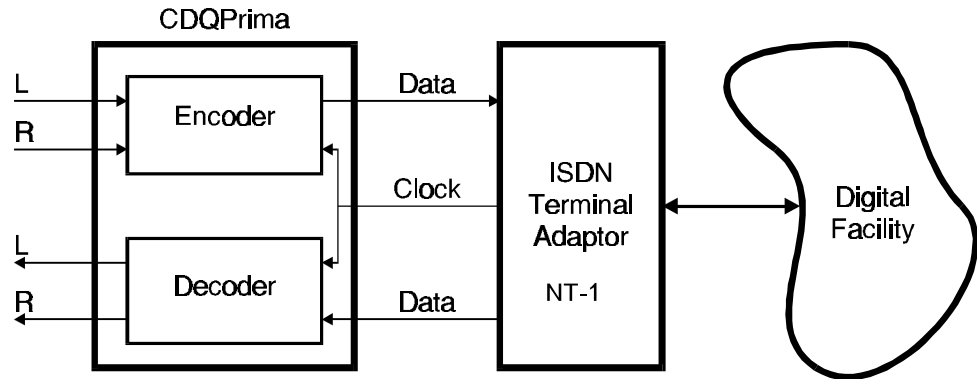

Figure 3-2 Basic Interconnection to Digital Network - X.21 interface

The X.21 interface specification is, in general, a very complex specification. The general specification allows a mechanism for communication between the customer equipment and the network. This communication path can be used for things such as dialing. A subset of the specification, called the leased circuit, restricts the interconnection to only clock and data and a very simple control signal. The mechanical connector required is the DB15 with the pin-out specified in the **CDQPrima Technical Reference Manual**. The electrical specification for X.21 is identical to those of RS422. The X.21 interface has only one clock for both the transmit and receive signals.

Since the X.21 uses the RS422 electrical interface, the **CDQPrima** can use the same connector and module for both interfaces. In the case of the X.21 interface, the single clock is used internally for both the transmit and receive timing. The selection of the type of digital interface is governed by software setup. See Chapter 5 for the appropriate settings. To change the hardware configuration of the DIF101 interface card between X.21 and RS422, change the position of jumper J4 on the interface module. The jumper on positions 1 and 2 is used for X.21, and when on positions 2 and 3, the card is set for RS422 operation.

3.1.3 ISDN Using the TA101 Digital Interface Module

The TA101 ISDN interface provides connections for one BRI S/T interface and requires an external NT-1 for North American operation.

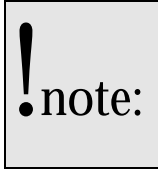

The TA101 provides basic ISDN Terminal Adapter functions and requires a different ROM for each country in which the CDQPrima will operate. Therefore, without changing ROM chips, the TA101 ISDN terminal adapter is portable only within a country. For example, a Terminal Adapter with a ROM for use in the United States cannot be used in Europe without changing the ROM.

Each TA101 ISDN interface adapter supports 2 ISDN 56 or 64 kb/s “B” channels that can be used independently or bonded together into a 112 or 128 kb/s channel. One single RJ-45 connector is used for the ISDN S/T connection to an external Network Termination (NT-1). See Chapter 5 for details on TA configuration.

The TA101 ISDN terminal adapter does not incorporate a built-in NT-1, which is required for connection to the ISDN network. In North America, it is the customers responsibility to provide the NT-1, elsewhere, the NT-1 is supplied by the service provider.

3.1.4 ISDN Using the TA201 or TA301 Digital Interface Module

The TA201 ISDN interface provides connections for one BRI S/T interface and requires an external NT-1 for North American operation. The TA301 is essentially the same as the TA201 but has a built-in NT-1 and therefore can only be used in North America and countries that require the user to provide an NT-1.

The TA201 has every country specific protocol software built in, and does not require any ROM chip changes to be used almost anywhere in the world. Each TA201 or TA301 ISDN interface adapter supports 2 ISDN 56 or 64 kb/s “B” channels that can be used independently or bonded together into a 112 or 128 kb/s channel. One single RJ-45 connector is used for the ISDN S/T connection to an external Network Termination (NT-1) on the TA201. The TA301 has one RJ-45 connector used for the ISDN ‘U’ connection directly to the North American ISDN network. See Chapter 5 for details on TA configuration.

3.2 Rear Panel Connectors

Refer to figure 3-3 for the locations and types of the connectors discussed below. The pin designations for all rear panel connectors can be found in the **CDQPrima** Technical Reference Manual.

3.2.1 Power & Power Switch (1, 2)

The power switch is used to control the main power to the **CDQPrima**. The **CDQPrima** is equipped with a world power supply, and operation is possible at all standard world voltages and mains frequencies. No internal or external adjustments or jumpers are required.

3.2.2 Analog Audio I/O (3, 4)

The **CDQPrima** provides 20 bit A/D converters for superior audio quality. The analog sections of the **CDQPrima** are set to +18 dBu maximum input levels. Other analog input and output levels are possible. Please contact MUSICAM USA if you require additional information or non-standard I/O levels or impedances. All **CDQPrima** models use industry standard XLR audio connectors for analog audio. Input impedance can be set to 600 ohms or >25 kOhms balanced. Output impedance can be set to 600 ohms or <60 ohms balanced.

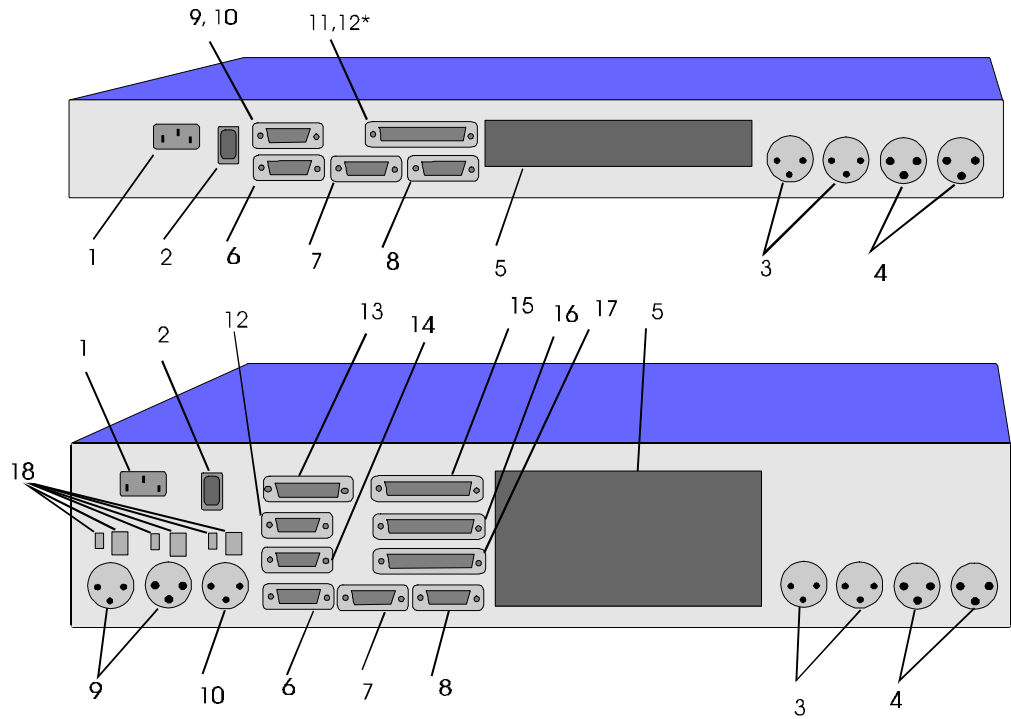

INDEX #	DESCRIPTION	CONNECTOR	COMMENTS
1	Power connector		
2	Power switch		
3	Analog audio output	XLR-M	
4	Analog audio input	XLR-F	
5	Digital interface module port(s)		1 on 100 series, 3 on 200 series
6	Alarms	DB9-M	
7	Remote control port	DB9-F	
8	Ancillary data port	DB9-M	
9	AES/EBU / S-PDIF Digital audio I/O	DB9-F	Optional on Model 110
10	AES/EBU Sync	XLR	200 series
		DB25-F	Shares connector on 100 series
11	Opto/relay I/O	XLR-F	200 series
		DB25-F	Optional
12	RS232 port	DB9-M	Second ancillary data port
13	Future use	DB15-M	
14	RS485 port	DB9-F	Custom applications only
15	Time code I/O	DB25	Optional
16	Relay outputs	DB25-F	Optional
17	Opto-isolator inputs	DB25-M	Optional
18	Optical I/O for AES/EBU audio and Sync	EAI-J	Optional

Figure 3-3 CDQPrima Rear Panel Connections

3.2.3 Digital Interface Module Ports (5)

CDQPrima 100 Series models accommodate a single Digital Interface Module (DIM), while the 200 Series models can hold up to three. Currently, five different Digital Interface Modules are available: TA101, TA201 and TA301 for ISDN, DIF101 for RS422/X.21 and DIF102 for V.35.

3.2.4 Alarm Port (6)

This is a DPDT relay output whose function is controlled by the RLS (Summary Alarm Relay) action. See the **CDQPrima** [Technical Reference Manual](#) for information on the use of this feature. These relay contacts are often used as a summary alarm output to indicate the failure of any major subsystem or loss of the transmission facility, but can be re-programmed using Prima Logic Language.

3.2.5 Remote Control Port (7)

This I/O port on the **CDQPrima** provides for either RS232 or RS485 remote control. It has the same RS232 capabilities as the front panel remote control port (on **CDQPrima** models 120, 220 and 230). The choice of the RS232 or RS485 interface can be made by a remote control command or a front panel keypad command. On the 200 Series models, the RS232 port supports full modem control. For a detailed description of all remote control commands, see the **CDQPrima** [Technical Reference Manual](#). A description of the required cables and the connector pin-outs can be found in the **CDQPrima** [Technical Reference Manual](#).

3.2.6 Ancillary Data Port (8)

The Ancillary Data connector provides an RS232 bi-directional interface for the transmission of asynchronous data. Data rates range from 300 to 38,400 bps. The data is transmitted in the same bit stream as the compressed audio. Refer to the **CDQPrima** [Technical Reference Manual](#) for the required RS232 cable configuration.

3.2.7 AES/EBU Digital Audio I/O (9, 10)

The AES/EBU professional digital audio interface standard provides a method to directly input and output digital audio. This standard allows interconnection of equipment without the need for Analog/Digital conversions. It is always best to reduce the number of A/D conversions since each time the conversion is performed, noise is generated.

The **CDQPrima** can also accept consumer standard S/PDIF digital audio I/O through the same connectors; however, the **CDQPrima** must be

reconfigured (three internal jumpers must be moved) for this. These jumpers, J5, J9 and J10, are located on the main circuit board behind the power supply. Use position “P” for professional AES/EBU digital audio (default), and position “C” for consumer grade S/PDIF digital audio.

On the **CDQPrima** 100 Series, the AES/EBU connector is a DB9 due to space considerations. The cable drawing for an adapter from the DB9 to standard XLR connectors are provided in the **CDQPrima** Technical Reference Manual. Adapter cables are available from MUSICAM USA. Please note that AES/EBU capability is an option on the **CDQPrima** 110. It is standard on all other models. **CDQPrima** 200 Series models are equipped with industry standard XLR connectors.

3.2.8 S/PDIF Digital Audio I/O (9, 10)

The consumer standard S/PDIF digital audio input and output share the same connectors as the professional standard AES/EBU digital audio. Three jumpers in the **CDQPrima** must be changed from the factory default to accommodate S/PDIF digital audio. These jumpers, labeled P5, P9 and P10, are located on the main circuit board behind the power supply. Simply lift the shorting blocks from the “P” position, and place them on the “C” position.

3.2.9 Opto/Relay I/O (100 Series) (11)

For space reasons in the **CDQPrima** 100 Series, the four optically isolated inputs (optional), four relay outputs (optional) have been combined into a single DB25-F connector. Refer to the **CDQPrima** Technical Reference Manual for the pin-out diagram.

3.2.10 RS232 Port (200 Series) (12)

The RS232 I/O DB9-M connector provides an additional port into the **CDQPrima**'s internal data multiplexer and/or the command processor. This port can be used as an additional RS232 ancillary data path. It is now possible to have two independent RS232 ancillary data paths. Details on using ancillary data can be found in the **CDQPrima** Technical Reference Manual.

3.2.11 Sync Data (200 Series) (13)

The synchronous data DB15-M port on **CDQPrima** 200 Series has been included for future use. Synchronous ancillary data is currently not supported.

3.2.12 RS485 Port (200 Series) (14)

The RS485 I/O DB9-F connector provides an additional port into the **CDQPrima**'s internal data multiplexer and/or the command processor. This port is available for ancillary data or custom applications. This port is not currently activated; however, if you need this port for a particular application, please contact MUSICAM USA.

3.2.13 SMPTE Time Code (200 Series) (15)

CDQPrima 200 Series units may be optionally equipped to transmit and receive SMPTE time code at standard rates of 24, 25, 29 and 30 frames per second, drop-frame is supported. The **CDQPrima** automatically detects the presence and type of time code at the encoder, converts it into a digital form and then multiplexes it into the ancillary data stream for transmission with the audio. At the decoder side, the ancillary data is separated from the audio and then de-multiplexed. The time code is then regenerated. SMPTE time code is bi-directional, and can work in conjunction with sending high quality, stereo audio with bit rates as low as 112 kb/s. Details for using this feature can be found in the [CDQPrima Technical Reference Manual](#).

3.2.14 Relay Outputs (200 Series) (16)

The optional relay outputs on **CDQPrima** 200 Series models are identical to those of the 100 Series except that the 200 Series may have up to eight relays. These dry contact relays may be controlled from the far end or by local events. In addition, fused 5 volts and ground levels are also available on the connector for pull-up and pull-down purposes. Refer to the [CDQPrima Technical Reference Manual](#) for the configuration of the DB25-F connector.

3.2.15 Optically Isolated Inputs (200 Series) (17)

The optional optically isolated inputs on **CDQPrima** 200 Series models are identical to those of the 100 Series, except the 200 Series units may be equipped with up to eight inputs. In addition, fused 5 volts and ground are also available on the connector. Refer to the [CDQPrima Technical Reference Manual](#) for the configuration of the DB25-M connector.

3.2.16 Optical Digital Audio I/O (18)

CDQPrima 200 Series models offer an optional optical digital audio interface. This interface uses EIA-J optical connectors. The *functions* of the EIA-J optical inputs are identical to the (electrical) AES/EBU or

S/PDIF digital input described above. The EIA-J connectors, when present, are enabled by a rear panel slide switch.