

TeamMate

USER MANUAL
for s/w versions 5.00 and later



INDEX

INTRODUCTION	6
<i>About this Manual.....</i>	<i>6</i>
1. Chapter 1 ABOUT TEAMMATE	7
<i>INTRODUCTION</i>	<i>7</i>
<i>TEAMMATE PARTS.....</i>	<i>8</i>
1.1.1 TeamMate Base Device	8
1.1.2 TeamMate Extension racks	10
2. Chapter 2 TeamMate Installation	11
2.1. <i>Before installing.....</i>	<i>11</i>
2.2. <i>Mounting in the rack.....</i>	<i>11</i>
2.3. <i>Installing the TeamMate</i>	<i>11</i>
2.3.1 Connecting the power	11
2.3.2 Connecting the controller card	13
2.3.3 Connecting the alarm relay:	17
2.3.4 Connecting the E1 or T1 lines:.....	18
2.3.5 Connecting the audio modules:.....	18
2.4. <i>Installing Extension Subracks.....</i>	<i>18</i>
2.4.1 Hot swapping of the extension modules:	20
2.5. <i>Starting up the TeamMate.....</i>	<i>20</i>
3. Chapter 3 Control Card.....	21
3.1. <i>Functional description.....</i>	<i>21</i>
3.2. <i>About E1/T1 Multiplexing.....</i>	<i>22</i>
3.2.1 Channels.....	22
3.2.2 Routes	22
3.3. <i>Configuring the master clock for the multiplexer</i>	<i>23</i>
3.4. <i>IP traffic through E1/T1 channels</i>	<i>23</i>
3.5. <i>GPO Connector</i>	<i>24</i>
3.6. <i>Alarm Relay Reset switch</i>	<i>24</i>
3.7. <i>Indicators on the Control Module.....</i>	<i>25</i>
4. Chapter 4 E1/T1 Module.....	26
4.1. <i>Functional description.....</i>	<i>26</i>
4.2. <i>Configuration.....</i>	<i>26</i>
4.2.1 E1 Interface:.....	26
4.2.2 T1 Interface	27
4.3. <i>Monitoring</i>	<i>27</i>
4.3.1 LEDES	27

5. Chapter 5 Audio Encoder Card	30
5.1. Functional description.....	30
5.2. Configuration.....	30
5.2.1 Coding algorithms.....	30
5.2.2 Selecting the audio source.....	35
5.2.3 Gain adjustment	35
5.2.4 Activating the test tone	35
5.3. Monitoring	35
5.3.1 LEDs.....	35
6. Chapter 6 Audio Decoder Card.....	36
6.1. Functional description.....	36
6.2. Configuration.....	36
6.2.1 Decoding algorithms	36
6.2.2 Selecting the audio output.....	41
6.2.3 Gain adjustment:	41
6.2.4 Activating the test tone:	41
6.3. Monitoring	41
6.3.1 LEDs.....	41
7. Chapter 7 Synchronous data card.....	42
7.1. Functional Description.....	42
7.2. Configuration.....	42
7.2.1 Installing the physical drivers	42
7.2.2 Speed selection.....	43
7.2.3 Control signals (Handshaking).....	43
7.3. Monitoring	44
7.3.1 LEDs.....	44
8. Chapter 8 Power Supply	45
8.1.1 Block Diagram of the power supply modules:.....	45
9. Chapter 9 Expansion Module	47
10. Appendix A Technical specifications.....	48
10.1. E1/T1 Module	48
10.1.1 E1 - Tx:	48
10.1.2 E1 - Rx:	48
10.1.3 T1 - Tx :	48
10.1.4 T1 - Rx:	49
10.2. Audio Encoder Module	50
10.2.1 Stereo audio input:	50
10.2.2 Audio properties:	50
10.2.3 Compression:	50
10.2.4 BANDWIDTH MPEG LAYER II.....	51
10.2.5 BANDWIDTH MPEG LAYER III.....	52
10.2.6 BANDWIDTH apt-X™	52
10.3. AUDIO DECODER MODULE.....	52

10.3.1 Stereo audio output:	52
10.3.2 Audio properties:	53
10.3.3 Compression:	53
10.3.4 Delays	54
<i>10.4. Synchronous data module</i>	<i>55</i>
10.4.1 Speed	55
10.4.2 Data format	55
10.4.3 Interface	55
10.4.4 Supported signals in the interface V35	55
10.4.5 Connector	55
<i>10.5. Power</i>	<i>55</i>
10.5.1 AC Power Supply:	55
10.5.2 DC Power Supply:	55
<i>10.6. Environmental</i>	<i>56</i>
<i>10.7. Physical</i>	<i>56</i>
10.7.1 Size	56
11. Appendix B Connectors	57
<i>11.1. E1/T1 Module</i>	<i>57</i>
<i>11.2. Control Module</i>	<i>58</i>
11.2.1 Console connector	58
11.2.2 GPO Connector	58
<i>11.3. Audio Encoder Module</i>	<i>59</i>
11.3.1 Audio XLR Connector:	59
11.3.2 Audio DB9 Connector:	59
11.3.3 Auxiliary data connector:	59
<i>11.4. Audio Encoder Module with two audio connectors</i>	<i>60</i>
11.4.1 AES/EBU:	60
11.4.2 Analog Audio:	60
<i>11.5. Audio Decoder Module</i>	<i>61</i>
11.5.1 Audio XLR connector:	61
11.5.2 Audio DB9 Connector:	61
11.5.3 Auxiliary data connector:	62
<i>11.6. Decoder module with two connectors</i>	<i>63</i>
11.6.1 AES/EBU:	63
11.6.2 Analog Audio:	63
<i>11.7. Data Module</i>	<i>64</i>
11.7.1 Data Connector	64
11.7.2 Cable description (SCSI-DB25)	64

INTRODUCTION

About this Manual

This manual provides information about the most important features of the TeamMate multiplexer. It also includes a customer installation guide and a reference guide to explain how the unit works and assist in its configuration. Users configuring the unit themselves should use either this manual or the CCS Remote Management configuration manual depending on whether configuration is made by console port (RS232) or LAN interface. CCS Remote Management is an optional SNMP based management application.

The sections in this manual are as follows:

- [About TeamMate](#): description of the more important features.
- [TeamMate parts](#): description of the component parts of the TeamMate.
- [TeamMate installation guide](#).
- [Control module](#).
- [E1/T1 module](#).
- [Audio Encoder Module](#).
- [Audio Decoder Module](#).
- [Appendix A](#): Technical specifications.
- [Appendix B](#): Connectors.

1. Chapter 1

ABOUT TEAMMATE

INTRODUCTION

TEAMMATE E1/T1 Multiplexer is a system that allows transportation of voice channels, high quality audio and data across 2.048 Mbps or 1.544 Mbps structured links (E1 or T1 circuits), using time division multiplexing (TDM). The TeamMate multiplexer supports up to four E1 or T1 links (two links for each installed E1/T1 interface card). It is possible to drop/insert time slots across any of the connected E1 circuits.

It is implemented using a modular construction with common backplane architecture in 19" rack. It is possible to cascade up to 8 racks together. This all gives great flexibility in the choice of input and output modules depending on the requirements of each application.

The more important features of the unit are as follows:

- Ability to connect up to four E1/T1 circuits to one base device.
- Drop/insert across any of the connected E1/T1 circuits.
- AC or DC (48V) power supply.
- Option of redundant AC or DC power supply.
- Hot swapping of modules to make servicing and updating easier.
- Option to extend the configuration with additional racks (up to a maximum of 8 racks).
- Local or remote control and configuration through RS232 (Telnet) or LAN interface (SNMP).
- Ability to assign time-slots for IP traffic dynamically. Routed interconnection of LAN through E1/T1 circuits.
- Totally configurable audio modules by software: selection of analog or digital interface as well as encoding/decoding algorithm.
- Bi-directional module of synchronous data (two ports per module). The interface can be configured V35/X21 and as DTE or DCE.

TEAMMATE PARTS

The TeamMate multiplexer is made up of a base device and additional racks where the number of modules is more than can be fitted in one rack. Below is a description of the individual parts and the position where they have to be fitted inside the rack.

1.1.1 TeamMate Base Device

1.1.1.1 Components

- **TeamMate frame:**
19"-4U Rack mount. The module slots are divided in 18 slots (1 slot = 0.8")
The back panel of the rack has identified connectors in the following way:
 - CN1: for the installation of the main power supply.
 - CN2: for the installation of the secondary power supply.
 - SLOTS 0-15: for the installation of the different modules. The using of these slots is subject to the following restrictions.

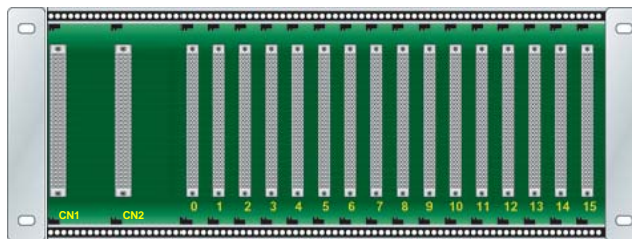

- **Main power supply:**
It is always installed in the connector CN1 of the back panel. The main power supply can be AC or DC.
- **Secondary power supply:**
It is always installed in the connector CN2 of the back panel. This power supply is optional and it is used as redundant in the case of failure of the main power supply. It can be AC or DC. It is installed next to the main power supply.
- **CONTROL module:**
This module looks after the configuration and monitoring of the system. It includes a GPO connector. It must be installed in the slot 13 or 14 of the main rack. It takes up one slot (0.8") of the frame.

- E1/T1 module:**
 E1 or T1 interface module accepts up to 2 daughter boards. Each line is identified as Line 1 and Line 2 and it has two BNC connectors, one for transmission (Tx) and one for reception (Rx) and a RJ45 connector. The TeamMate allows two modules (up to four E1 or T1 links) they must be installed in the slots 0 and 1 of the rack. Each module takes one slot.
- Audio ENCODER module:**
 This module carries out the encoding process. All its parameters are configurable by software: analog or digital input and coding algorithm. This module can be installed in any of the slots 2-13 of the rack. It can also be installed in the slot 14 when this is not be occupied by the control module. Each module takes two slots when the connectors are XLR or only one slot if the module is supplied with 9 way sub D connectors.
- Audio DECODER module:**
 This module carries out the decoding process. All of it's parameters are configurable by software: analog or digital output and decoding algorithm. This module can be installed in any of the slots 2-13 of the rack. It can also be installed in the slot 14 when the control module does not occupy this. Each module takes two slots when the connectors are XLR or only one slot if the module is supplied with 9 way sub D connectors.
- SYNCHRONOUS DATA module:**
 The interface is X21/V35 and can work as DCE or DTE. Each module has two data ports. This module can be installed in any of the slots 2-13 of the rack. It can also be installed in the slot 14 when it is not occupied by the control module or in the slot 15 if the expansion module is not fitted. Each module takes up one slot.
- EXTENSION module:**
 This module is needed to connect more than one frame. This module must be installed in the slot 15 of the main rack and in slots 0 and 15 of the secondary racks. This module takes up one slot.
 Below is a summary of the restrictions on the position of the modules that can be installed in the TeamMate rack:

Main Rack	
MODULE	Position in the rack
Main power supply (AC or DC)	Connector CN1
Secondary power supply (AC or DC)	Connector CN2
E1/T1 module	Slots 0 – 1
Audio Encoder Module	Slots 2-14
Audio Decoder Module	Slots 2-14

Data Module	Slots 2-15
Control Module	Slots 13 – 14
Expansion Module	Slot 15

Table I: Configuration of the TeamMate Main rack

Secondary Racks	
MODULE	Position in the rack
Main power supply (AC or DC)	Connector CN1
Secondary power supply (AC or DC)	Connector CN2
Audio Encoder Module	Slots 1..14
Audio Decoder Module	Slots 1..14
Data Module	Slots 1..14
Expansion Module	Slot 0 & 15 depending on the configuration.

Table II: Configuration of the TeamMate secondary rack

1.1.2 TeamMate Extension racks

There is an option to extend the number of audio or data modules by connecting additional racks using the expansion module. Each of these racks has its own independent power supply, and the ability to also install a redundant power supply.

In the case of further expansion racks, it will be necessary to install expansion modules in order to allow racks to be connected in cascade. The expansion modules are fitted in the slots 15 and 0 of the backplane. It is possible to install audio as well as data modules in the rest of the slots of the backplane (1-14).

E1/T1 or control modules cannot be installed in the expansion racks.

2. Chapter 2 TeamMate Installation

2.1. Before installing

The TeamMate unit can be shipped pre-configured to the customer's specification. It is recommended that you check that the shipped configuration is as requested.

2.2. Mounting in the rack

The TeamMate requires 4U rack (4U = 7"). We recommend when installing the TeamMate, to leave a free space in its upper and lower part to guarantee a correct ventilation of the unit.

2.3. Installing the TeamMate

All the connections of the TeamMate, with the exception of the power, are accessible from the front of the unit. None of the cards, with the exception of the power supplies, requires the configuration of jumpers or switches.

2.3.1 Connecting the power

The TeamMate rack allows installation of an AC or DC main and/or redundant power supply. The rack is supplied with the customer specified configuration of power supplies. It is important that the end user checks which power supply/supplies are installed before using the unit.

The power connections for both the AC and DC power supplies are located on the rear panel of the TeamMate rack. There are two power input connectors for each type of power supply i.e. The AC IEC connectors feeds both AC power supplies and the DC connectors feeds both DC supplies.

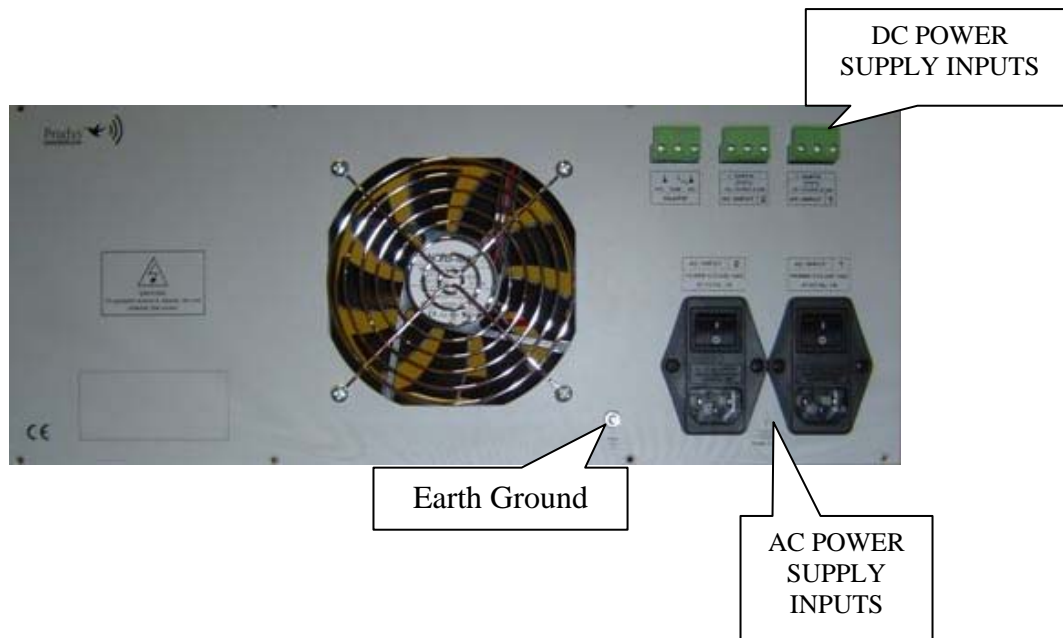

2.3.1.1 Connecting the 48 VDC power supply

The 48VDC connectors are located in the rear panel of the TeamMate. The unit is supplied with this connectors to ease the installation. The connection procedure is as follows:

- 1.- Only use UL 12 AWG standardized cable. We recommend stripping the cable approximately 8 mm (3 inches).
- 2.- Ensure that the external power supply or battery is disconnected.
- 3.- Connect the GND screw to the installation ground.
- 4.- Connect the negative terminal of the external power supply to the - connection point of the DC INPUT connector.
- 5.- Connect the positive terminal of the external power supply to the installation ground and to the +connection point of the DC INPUT connector.

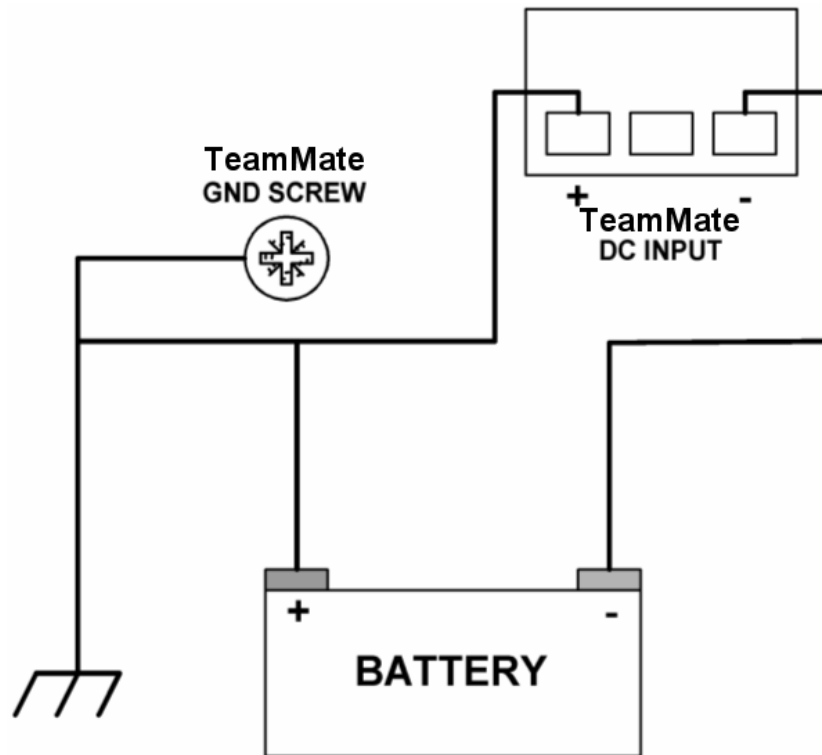

ATTENTION:

Extra precautions must be taken when connecting the DC power supply. A wrong installation could damage the unit.

Make sure that there no voltage in the DC power supply cable before you connect it.

2.3.2 Connecting the controller card

The control card has two connectors (CON & LAN) in order to allow management of the TeamMate. Depending on which one is used, the access to the configuration and management functions of the TeamMate are different.

2.3.2.1 Management for console: CON connector

The CON connector provides a serial port connection. It acts as DCE. The terminal that is connected to that port, must be configured as below:

Protocol: UART
 Line speed: 9600 bps
 Parity: None
 Data Bits: 8
 Stop Bits: 1
 Flow control: None
 Terminal Emulation: VT-100

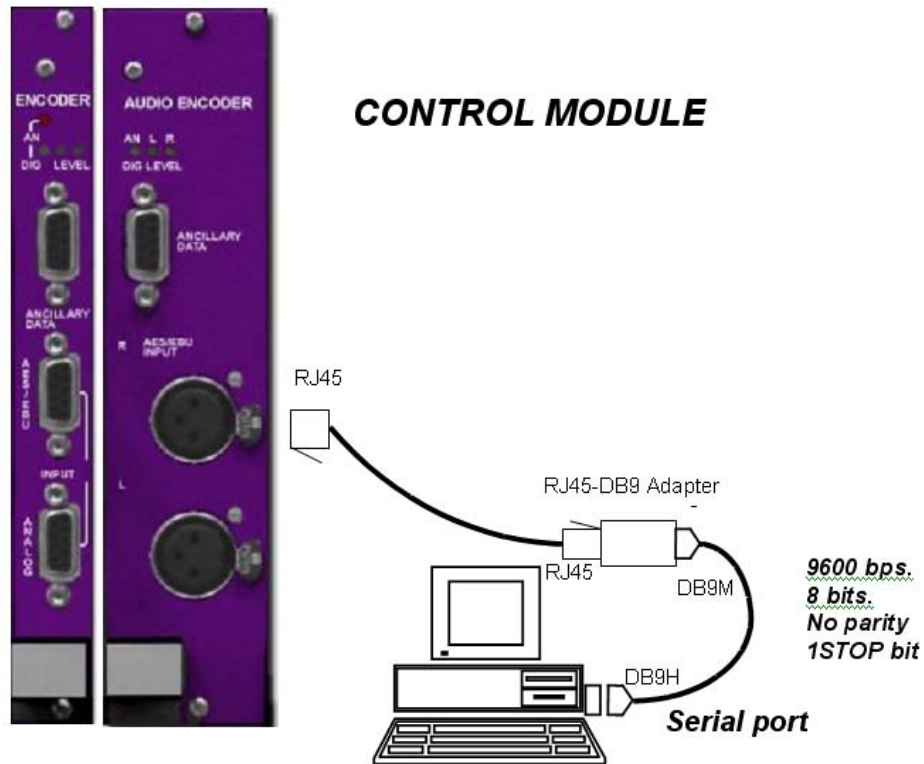

2.3.2.2 Remote management: LAN connector

The Controller card has a TCP/IP stack, which allows remote management via:

- TELNET service: Emulates the serial port console.
- SNMP service: Allows centralized management of the unit with software, typically CCS Remote Management Software.

Remote management can be carried out using the Ethernet Interface (LAN connector) through E1/T1 channels, at least one time slot needs to be configured to support IP traffic.

Management of local TeamMate units (those connected to our LAN through the TeamMate LAN connector) as well as of remote TeamMate units can be carried out, since the TeamMate routes the IP traffic through the E1/T1 links.

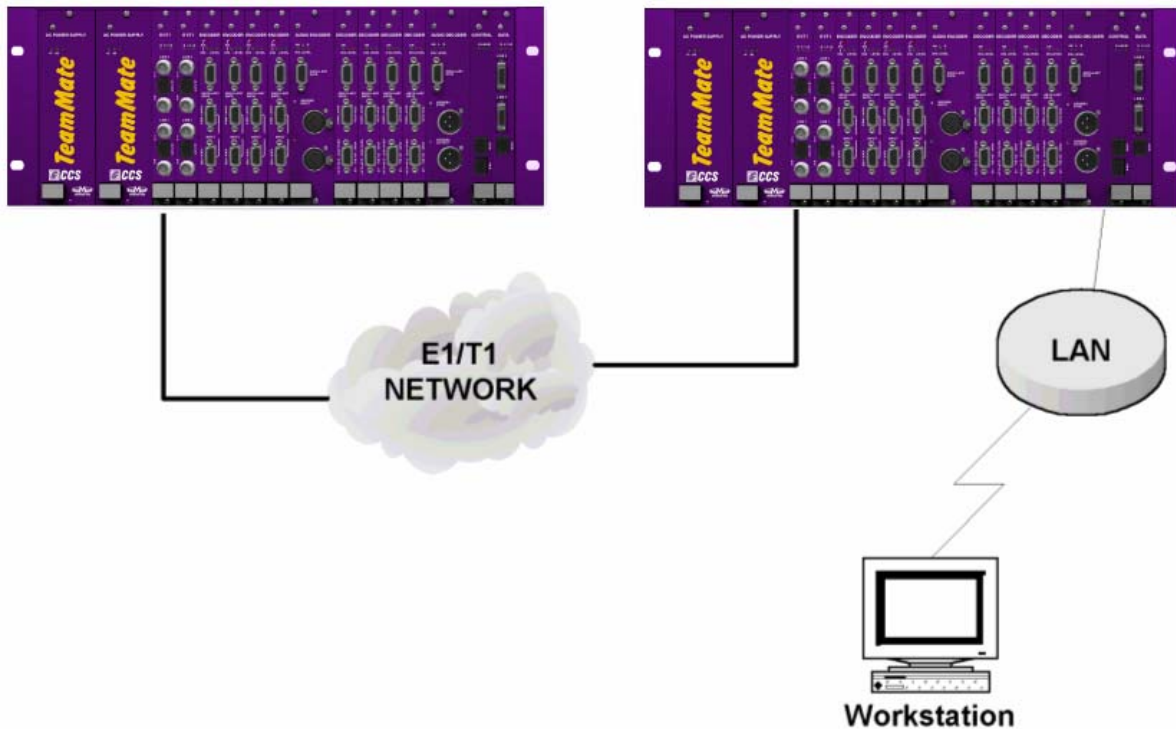

MUSICAM USA can supply an application for the management of the TeamMate (CCS Remote Management) it allows access to the control and monitoring functions of the TeamMate unit.

If you connect a network card (Workstation) to the LAN interface of the TeamMate, you must use a cross-over LAN cable.

IP protocol Configuration:

The TeamMate unit is supplied with the IP address and mask pre-configured. The end user can change the IP address and mask using the CCS Remote Management or console connector and terminal emulation software. To use the console software, the steps are as follow:

- 1.- Connect a terminal to the CON connector (RJ45) on the control module as is described in the Chapter "Management from console".
- 2.- At the prompt that appears on the terminal screen, type the following:
(The commands that you enter are typically shown as "*command* ↵" followed by the Enter key)

```
*process 4 ↵
Config> protocol ip ↵
Internet protocol user configuration
Ip Config>
```

3.- **Ip Config>** indicates that you are in the IP protocol configuration menu.

To check the current IP address and mask:

```
IP Config>list all ↵
```

The following will appear:

Interface addresses

IP addresses for each interface:

```
intf 0 192.1.2.3 255.255.255.0 NETWORK broadcast, fill 0
intf 1 IP disabled on this interface
```

Routing

```
Route to 0.0.0.0,0.0.0.0 via 192.1.2.1, cost 0
```

Protocols

```
Directed broadcasts: enabled
```

```
RIP: enabled
```

```
OSPF: disabled
```

```
Per-packet-multipath: disabled
```

```
Ip classless: disabled
```

The programmed information related to the IP address and mask appears associated to the 0 (intf 0) interface.

To change the IP address and mask:

```
IP Config>change address ↵
```

The following screen will appear:

```
New address to be changed [0.0.0.0]?
```

Type the new IP address:

```
New address to be changed [0.0.0.0] 192.1.2.4 ↵
```

```
Address mask [255.255.0.0]?
```

Type the new mask:

```
Address mask [255.255.0.0] 255.255.0.0 ↵
```

Following, it is needed to program the internal IP address which value will be the same as the one previously entered:

```
IP Config>set internal-ip-address
```

```
Internal IP address [192.1.2.4]? 192.1.2.4
```

IP Config>

To quit the configuration menu:

IP Config>exit ↵

Config>

To save the new configuration:

Config>save ↵

Save configuration [n]? Yes ↵

Saving configuration...Ok

Config>

Leave the configuration menu by pressing the **CTRL-P** keys simultaneously to restart the control module:

***restart**

Are you sure to restart the system?(Yes/No)? Yes ↵

There is a DB15 connector in the front panel of the Control module. This connector offers a seven general purpose opto-isolated outputs to be activated remotely. There is also a switch to disable the alarm relay located on the rear panel.

2.3.3 Connecting the alarm relay:

If an alarm condition is present, TeamMate will activate the alarm relay. When an alarm condition is detected, the normally open contact will be closed.



The alarm cut-off switch is located on the Control module front. This switch could be used to silence a local alarm once the source of the alarm has been identified and deactivated.

2.3.4 Connecting the E1 or T1 lines:

The TeamMate allows up to four E1 or T1 circuits to be connected. Each E1 module has two interfaces, installing a daughter card on the baseboard for each interface enables these. There is the option of using either BNC or RJ45 connectors for each interface.

2.3.5 Connecting the audio modules:

The audio modules are configurable by software, even the type of input or output. Each module supports analog as well as digital interface. A LED on the front of the module indicates the interface that is active. Which connector is in use depends on the mode selected.

2.3.5.1 Audio Encoder Module:

- Analog inputs: AN/DIG led is light indicating that the analog interface is active. The connections are the same as the panel markings. i.e. L and R.
- Digital input: AN/DIG led is off indicating that the digital interface is active. The AES/EBU audio input is connected to the connector marked AES/EBU INPUT.

In the 1-slot version(db-9) encoder modules there are two independent audio inputs, for analog and digital signals. These modules have a switch on the front panel, to change from analog to digital audio source and vice versa.

2.3.5.2 Audio Decoder Module:

- Analog outputs: LED AN/DIG is lit indicating that the analog interface is active. The connections are the same as the panel markings. i.e. L and R.
- Digital output: AN/DIG LED is off indicating that the digital interface is active. The AES/EBU audio output connected to the connector marked AES/EBU OUTPUT. Optionally to lock to an external sync source use the connector with marked AES/EBU SYNC.

In the new decoder modules there are two independent audio outputs, for analog and digital signals.

2.4. Installing Extension Subracks

There is the possibility to increase the number of audio or data modules by connecting in cascade additional racks using the extension modules. Each rack has an independent power supply with the possibility to install a secondary one as well.

It will be necessary to install in the extension racks, extension modules to allow the connection in cascade. The extension modules will always be inserted in slots 15

and 0 in the back panel. It will be possible to install as many audio modules as data modules in the remaining slots free (1...14) in the back panel.

The connection between subracks will be made by using a standard 50 ways SCSI cable.

This cable is supplied together with the units, if requested according to the configuration inquired by the user.

The way to interconnect the subracks will be as follows:

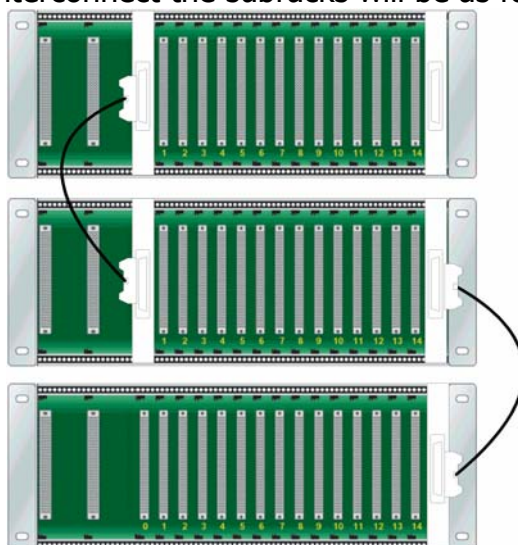

ATTENTION:
The last connected subrack needs an additional extension board (without connection cable) for bus termination.

The extension boards have some jumpers which configuration depends on the subrack they are installed in and the slots they occupy. Please see this configuration as follows:

Jumpers configuration of the Extension board				
Subrack	Slot	Jumper P1	Jumper P2	Jumper P3
0 (Main Subrack)	15	OPEN	OPEN	OPEN
1,3,5,7	15	CLOSED	CLOSED	OPEN
1,3,5,7 (If it is the last subrack)	0	OPEN	OPEN	CLOSED
1,3,5,7 (If it is not the last subrack)	0	OPEN	OPEN	OPEN
2,4,6,8	0	CLOSED	OPEN	OPEN
2,4,6,8	15	OPEN	OPEN	OPEN

2.4.1 Hot swapping of the extension modules:

ATTENTION:

The removal of one of the extension boards will interrupt the operation of the whole system if the interconnection cable has not been unplugged.

When an extension board needs to be replaced, first unplug the interconnection cable to allow operation of the other modules installed in the rest of the subracks.

2.5. Starting up the TeamMate

The startup sequence takes about 30 seconds. During the startup sequence, the control module starts up and detects the configuration of the TeamMate, loading the saved configuration or the default configuration if it finds a newly installed module.

3. Chapter 3 Control Card

3.1. Functional description

The main function of the Controller Card is to allow the management of the TEAMMATE. **Management** can be carried out **LOCALLY** as well as **REMOTELY**. For local management, the Controller Card has a Serial Port and for remote management, it has an ETHERNET LAN interface. The Controller card also provides with the following features:

- **Control of the TEAMMATE clock.**

The Controller Card monitors the state of the E1/T1 Line clocks and generates the Master clock for the TEAMMATE. If the line clock fails, the next active clock is assigned as Master clock.

- **Auto configuration of hot-plugged modules.**

When a card is inserted in to the Frame, the controller Card detects it automatically and configures the switching routes. In that way this card does not interfere with the current status of the unit. If the configuration is valid, it will start working immediately.

- **Auto configuration of the interchanged cards.**

If a faulty module is replaced, the Controller card detects the new one and the configuration is restored, the new card works to the same configuration as the faulty one.

- **Management of remote units.**

In situations where there are two or more installed TEAMMATE units, network (IP) connectivity through E1/T1 can be configured. The controller card adds the ability to use E1/T1 time slots for transportation of IP data in order to allow configuration of remote units. You can manage the remote units using Telnet or SNMP.

3.2. About E1/T1 Multiplexing

TeamMate multiplexes/demultiplexes structured E1/T1 circuit data (G.703 / G.704). Two concepts need to be understood in order to carry out configuration: **Channel** and **Route**.

These two elements are all that are necessary to fully define a multiplexed configuration.

3.2.1 Channels

A channel is a data flow (bits) at a speed of $N \times 64$ kbps, where N is less than 32. The user must define the channel before setting the route.

- **E1/T1 channels:**

An E1/T1 channel is a "multiple 64 kbps" in one direction only, that is, N time-slots of one received or transmitted E1/T1 line. A channel transports a sequential flow of bits through an E1/T1 line at a speed of $N \times 64$ kbps.

The channels are defined by the user and must specify the following:

- Which E1/T1 line is to be used as well as the direction of the communication input (Rx) or output (Tx).
- Which time-slots make up the channel? The order in which they are specified does not matter, as the bits are always taken in the order they received or transmitted through the E1/T1 circuit.

3.2.2 Routes

A route is the connection from input module to channel (groupings of E1 or T1 time slots) to output module (Audio or Data) or visa versa. According to the kind of the channel defined, the mode of operation is called multiplexed, demultiplexed or drop/insert.

Type of source channel	Type of destination channel	Mode Operation
E1/T1	Output module	Demultiplexed
Input module	E1/T1	Multiplexed
E1/T1	E1/T1	Drop/insert

It is necessary to define the channels at each end of the E1/T1 circuit. Both channels of a route must have the same bandwidth (effective speed), and time slot allocation. You cannot define more than one route with the same destination.

However, You can define more than one route with the same origin and different destination channels, in other words distribution.

3.3. Configuring the master clock for the multiplexer

The TEAMMATE multiplexer uses one clock source at a time, the currently active clock source is called the MASTER clock. The source of the clock is configurable, there are up to eight possible sources that can be used as MASTER clock for the Multiplexer, they are as follows:

- ❑ A clock for each E1/T1 link that is recovered from the line i.e. up to 4 external clocks (normal operation is to 'lock' to the clock supplied by the Telco).
- ❑ An internal clock for each E1/T1 link that is from a crystal on the E1/T1 module i.e. up to 4 internal clocks.

The different sources are:

Clock ID	Source
1	Clock from Line 1 of module in slot 0
I1	Internal clock from Line 1 of module in slot 0
2	Clock from Line 2 of module in slot 0
I2	Internal clock from Line 2 of module in slot 0
3	Clock from Line 1 of module in slot 1
I3	Internal clock from Line 1 of module in slot 1
4	Clock from Line 2 of module in slot 1
I4	Internal clock from Line 2 of module in slot 1

In order to set the MASTER clock that the TEAMMATE will use, you must assign priorities for each of the available clock sources. The priority is based on a list of clocks where the top element is the highest priority and the bottom one, the lowest priority. In order to assign a priority within the CCS Remote Management application, each clock can be moved in relation to each other.

3.4. IP traffic through E1/T1 channels

The controller card is able to communicate by IP with remote units through E1/T1 channels. It is possible to access the whole network of TEAMMATE units for centralized management and configuration from an only one management application, as the controller is also a router this allows the interconnection of networks using those links.

In order to get IP access through E1/T1 channels, there is an internal line in the control module. This is a line of 1280 Kbps (20 timeslots) that is multiplexed to the four E1/T1 lines of the TEAMMATE. On this internal line there are PPP interfaces, one for each IP channel (bi-directional) that we want to establish. TeamMate units are supplied with the pre-configured PPP connections. The user only has to assign time slots for the IP traffic in each one of the available E1/T1 lines. Note the maximum number of time slots is 20 (summing the time slots of all the lines).

3.5. GPO Connector

A subD 15 pin socket provides a general purpose connection with 7 general purpose opto-isolated outputs. The connections must be wired according to the following diagram:

PIN	SIGNAL	PIN	SIGNAL
1	Output 1	9	GND1
2	Output 2	10	GND2
3	Output 3	11	GND3
4	Output 4	12	GND4
5	Output 5	13	GND5
6	Output 6	14	GND6
7	Output 7	15	GND7

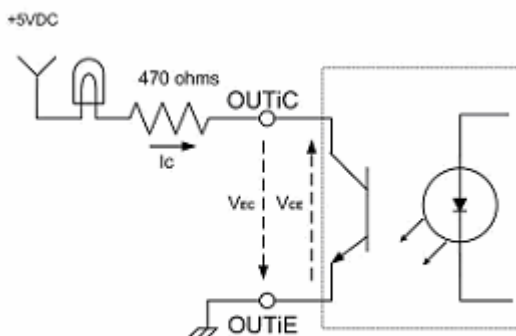

Opto-isolated output connection

Technical specifications
$I_{cmax} = 50 \text{ mA}$.
$V_{cemax} = 70 \text{ V}$; $V_{ecmax} = 7 \text{ V}$.
$P_{max} = 150 \text{ mW}$.

3.6. Alarm Relay Reset switch

There is a switch on the frontal panel to reset the alarm relay located on the rear panel. The switch only has effect if the alarm condition is finished.

3.7. Indicators on the Control Module

The control module has three LEDs on its front panel.

S	Status of the Control Card: Green: Ok Red: Not Ok.
LAN	Status of the Ethernet connection: Green: Connected to LAN. Red: No connection.
M	Not used.

4. Chapter 4 E1/T1 Module

4.1. Functional description

Each E1/T1 card is able to manage up to two structured E1/T1 bi-directional links, following the G.703/G.704 recommendations. The card has the following functions:

- Data reception/transmission through E1/T1 circuits.
- Provide the master clock to the multiplexer.
- E1/T1 drop/insert.

4.2. Configuration

The E1/T1 module detects the installed interface daughter board (E1 or T1) and provides access to the correct configuration parameters for each.

4.2.1 E1 Interface:

The following parameters can be configured:

Option	Value by default	Description
CRC4	Enable	Automatic generation of bits VRC-4. The received bits VRC-4 will also be monitored and the LED of the front panel will be updated.
Line Impedance	75 ohm.	It is possible to select: <ul style="list-style-type: none">• 75 ohm unbalanced (BNC connector).• 120 ohm balanced (RJ11 connector)

ATTENTION:

The line impedance selection requires also the configuration of the P1 jumper located on the E1 modules.

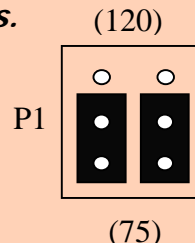

4.2.2 T1 Interface

For the T1 interface it is necessary to configure the length of the attached cable. The available options are as follows:

- 0-133 ft (41m.)
- 133-266 ft. (81m.)
- 266-399 ft. (122 m.)
- 399-533 ft. (162 m.)
- 533-655 ft. (183 m.)

4.3. Monitoring

The E1/T1 module provides status information as below:

LINE STATUS	DESCRIPTION
DOWN	Line data not detected
DATA DETECT	Line data has been detected but the frame synchronization has not been detected
UP	Line data has been detected and frame has been synchronized
RESYNC	The frame synchronization has been lost. System is trying to synchronize again
NOT_PRESENT	G703 Daughter board has not been detected correctly.

4.3.1 LEDS

The E1/T1 card has three LEDs to indicate its status.

LINE 1	Line 1 status
LINE 2	Line 2 status
S	Clock configuration

4.3.1.1 Line status

LINE 1 or LINE 2	STATUS
RED (solid)	G703 daughter card Not detected
RED (blinking)	Line DOWN
GREEN (blinking)	Line UP
YELLOW (blinking)	Line in loop

4.3.1.2 Clock configuration

S	CLOCK
RED (solid)	Wrong MASTER clock L1 and L2 RED (solid).
GREEN (blinking)	Card generating MASTER clock
YELLOW (blinking)	Card receiving clock.
RED-YELLOW	Connecting internal PLL L1 and L2 YELLOW (solid).



5. Chapter 5

Audio Encoder Card

5.1. Functional description

The audio encoder module allows the transmission of audio signals through the E1/T1 circuits in different compression formats. All the parameters are configurable by software even the selection of the analog or digital interface (AES/EBU). A single encoder module can access the four E1/T1 line interfaces using independent channels simultaneously, i.e. the time slots used on each line can be different.

5.2. Configuration

The configuration options for the audio encoder module depend on the compression algorithm that is selected. The two audio channels of each encoder can be used as two independent encoders each using a different algorithm, or encoding each audio input using the same algorithm but using a different bit rate for each input.

5.2.1 Coding algorithms

5.2.1.1 G711:

It allows the transmission of audio signals using the standard of telephone transmission (bandwidth 3.4 KHz). Using G711, each audio input takes up a single time slot of an E1/T1 link (64 Kbps). Each audio input in G711 mode can be either A-Law or μ -Law.

5.2.1.2 G722:

Allows the transmission of high quality voice signal (7 KHz). Using G722, each audio input takes up a single time slot of an E1/T1 link (64 Kbps). Synchronization can be selected between statistical framed (SRT) or H221.

5.2.1.3 MPEG:

Depending on the selected configuration, the bandwidth as well as the delay will change. Both parameters are explained in the technical specification section. The encoder module allows the following MPEG encoding formats:

- LAYER: II or III
- FREQUENCY: 16, 24, 32 or 48 KHz.
- BITRATE: 64, 128, 192, 256, 320 or 384 Kbps.
- MODE: Stereo, Joint Stereo, Dual or Mono.

The allowed sampling frequency, bit rate and mode combinations will depend on the imposed restrictions by the MPEG standard. They are as follows:

		MPEG LAYER II Fs = 48/32 KHz			
		MODE			
		Stereo	Joint Stereo	Dual	Mono
B R A T E	64	X	X	X	X
	128	X	X	X	X
	192	X	X	X	X
	256	X	X	X	
	320	X	X	X	
	384	X	X	X	

		MPEG LAYER II Fs = 24/16 KHz			
		MODE			
		Stereo	Joint Stereo	Dual	Mono
B R A T E	64	X	X	X	X
	128	X	X	X	X
	192				
	256				
	320				
	384				

		MPEG LAYER III Fs = 48/32 KHz			
		MODE			
		Stereo	Joint Stereo	Dual	Mono
B R A T E	64	X	X	X	X
	128	X	X	X	X
	192	X	X	X	X
	256	X	X	X	X
	320	X	X	X	X
	384				

		MPEG LAYER III Fs = 24/16 KHz			
		MODE			
		Stereo	Joint Stereo	Dual	Mono
B R A T E	64	X	X	X	X
	128	X	X	X	X
	192				
	256				
	320				
	384				

It is also possible to enable auxiliary data with the following options:
 NO DATA, 300, 1200, 2400, 4800, 9600 or 19200 bps.
 Each module has a DB9 connector to transmit auxiliary data.

There is only one auxiliary data channel available per module. However, when working in 2 codecs mode, the auxiliary data can independently be enabled in each codec.

5.2.1.4 J41:

The J.41 standard is recommended for encoding 15KHz mono analog signals for digital transmission at 384Kbit/s. You can use 2 mono digital codecs for stereo. The J.41 standard encoding laws are based on a uniformly quantized 14-bit per sample PCM technique with companding and employ eleven-segment 14- to 11-bit instantaneous A-law companding. There is also a parity bit for error detection. It is calculated from the 5 most significant bits of the sample. For each 2 input samples we get an output code.

There are 2 variants of the standard:

- Variant, A which is used in units that are based on a hierarchy at 2048Kbit/s (E1).
- Variant B, which is used in digital units that are based on a digital hierarchy at 1544Kbit/s (T1).

There is an option for setting emphasis on the audio signals according to recommendation J.17. Also the recommendation G.735 for channel (time slot) allocation can be set.

Special compensation mode delays for compatibility with other multiplexers (only for J.41):

In order to be compatible with other manufacturers multiplexers a special mode can be selected that introduces a delay between the two channels. This ensures that the audio channels are phase coherent when connecting a TeamMate unit to other manufacturers multiplexers. The delay offset between L and R channels of a module depends on the assignment of time slots that are selected for each audio channel. This assignment must be made according to the G.735 standard.

- A→ 1,2,3 – 17,18,19 slots.**
- B→ 4,5,6 – 20,21,22 slots.**
- C→ 7,8,9 – 23,24,25 slots.**
- D→ 10,11,12 – 26,27,28 slots.**
- E→ 13,14,15 – 29,30,31 slots.**

Depending the selected group for the L channel, the assignment of time slots for the R channel, should be chosen from the table below:

	A	B	C	D	E
A	X	11.72 μ S	23.44 μ S	35.16 μ S	46.88 μ S
B	-	X	11.72 μ S	23.44 μ S	35.16 μ S
C	-	-	X	11.72 μ S	23.44 μ S
D	-	-	-	X	11.72 μ S
E	-	-	-	-	X

The time slots that have been assigned to the L channel are in the left column and the slots to be assigned to the R channel are along the top. The values indicate the compensated delay for each combination.

5.2.1.5 J42:

The J.42 standard is recommended for encoding 7KHz mono analog signals for digital transmission 192Kbit/s. The J.42 standard encoding laws are based on a uniformly quantized 14-bit per sample PCM technique with companding and employ eleven-segment 14- to 11-bit instantaneous A-law companding. There is also a parity bit for error detection. It is calculated from the 7 most significant bits of the sample. For each 2 input samples we get an output code.

There are 2 variants of the standard:

- Variant, A which is used in units that are based on a hierarchy at 2048Kbit/s (E1).
- Variant B, which is used in digital units that are based on a digital hierarchy at 1544Kbit/s (T1).

There is an option for setting emphasis on the audio signals according to recommendation J.17. In the case of the stereo, only one digital channel at 384Kbit/s is used, joining the signals of both channels according to J.41 standard.

5.2.1.6 J57:

The ITU-T J.57 recommendation is used for the transmission of digital sound signals with studio quality by digital hierarchy H11 or H12. The J.57 (H12) standard encoder receives 20bit samples of stereo digital audio at 48KHz. It encodes blocks of 96 audio samples (48 per channel). Giving a 1ms companding block, near instantaneous companding from 20 to 15 bits/sample is applied with 8 coding ranges. Each coded sample has a parity bit (96 parity bits per 1ms companding block) some of these bits are used in order to transmit the scale factor information for each channel, the status of the channel, additional data and MultiFrame Alignment signals (every 1536bits or 192 blocks = 192ms), MFA, and frame slip detection, FSD (in each block of 1 ms). In the case of H12, 3 audio bits and 1 user bit per sample are sent. The H12 level provides a total of 20 bits per sample, and H11 provides a total of 16 bits per sample. To simplify interworking between H11 and H12 channels, the companding of the audio signal is such that the samples are compressed for transmission in the H11 channel. In the H12 channel, extra bits may be conveyed, to improve resolution of the audio coding and provide a user data channel. H11 uses 24 time slots and H12 30 at 64 Kbps.

5.2.1.7 apt-X™: Standard & Enhanced

**This option is not available in the standard version.
For more information, contact support@musicamusa.com**

It allows the transmission of audio with similar quality to linear PCM but at a much reduced bit-rate. apt-X™ is a low complexity audio compression algorithm offering unsurpassed audio quality, it is robust to random bits errors, extremely tolerant to tandem coding and has short coding delay. The apt-X™ system is based on an implementation of subband Adaptive Differential Pulse Code Modulation, (Subband ADPCM). The Standard apt-X™ transparently code 16-bit PCM audio with a fixed compression ratio of 4:1. Also, there are three improved versions, Enhanced apt-X™, offering further levels of operation with a choice of 16, 20 or 24 bit resolution. These Enhanced versions deliver a significant improvement in audio an processing delay performance coupled with faster synchronization and a new method for embedding auxiliary data.

Depending on the selected algorithm (Standard or Enhanced) and sampling frequency the delay will change. The bandwidth depends just on sampling frequency. Both parameters are explained in the technical specification section. The encoder module allows the following apt-X™ encoding formats:

- Standard, Enhanced 16 bits, Enhanced 20 bits or Enhanced 24 bits apt-X™.
- FREQUENCY: 16, 32 or 48 KHz.
- BITRATE: 64, 128, 192, 256, 320, 384 or 576 Kbps.
- MODE: Mono or Stereo.

The bit rate depends on the number of audio channels, sampling frequency and apt-X™ algorithm. They are as follows:

FREQUENCY	MODE	apt-X Standard	apt-X Enhanced		
			16 bits	20 bits	24 bits
16 kHz	mono	64 kbps	64 kbps	-	-
16 kHz	stereo	128 kbps	128 kbps	-	192 kbps
32 kHz	mono	128 kbps	128 kbps	-	192 kbps
32 kHz	stereo	256 kbps	256 kbps	320 kbps	384 kbps
48 kHz	mono	192 kbps	192 kbps	-	-
48 kHz	stereo	384 kbps	384 kbps	-	576 kbps

Note: modes marked with "-" are not allowed, because they have bit rates not multiple of 64 kbps.

It is also possible to enable auxiliary data with the following options:

NO DATA, 300, 1200, 2400, 4800, 9600 or 19200 bps.

Each module has a DB9 connector to transmit auxiliary data.

There is only one auxiliary data channel available per module.

5.2.2 Selecting the audio source

The audio source can be selected between analog or digital. It is configurable both by software and from a switch on the front of the module. The audio input selected is indicated in a led on the front panel of the module as follows:

ANA/DIG LED: Green means analog audio input selected.
Red indicates digital audio input selected.

A new possibility has been added for the new encoder modules with analog and digital audio connectors: It is possible to enable the audio source backup. In that way, if a threshold is not detected in a specified time, the input will be switched.

Additionally an alarm can be activated to monitor whether the audio input source has been switched.

5.2.3 Gain adjustment

The gain of each channel can be adjusted between +6 and -6 dB in steps of 1dB.

5.2.4 Activating the test tone

We can active or deactivate a test tone of 1004 Hz and -12 dBFs in each channel.

This tone will replace the input audio to all intents and purposes (VU meters, coding...), but will not be affected by the volume control.

5.3. Monitoring

5.3.1 LEDs

There are three LED's in the front of each module:

AN/DIG	If the LED is GREEN , it indicates that the analog input is selected. If it is RED , it indicates AES/EBU input is selected.
L	Level indicator: OFF: < -78 dBFs (no audio input). GREEN: -78 dBFs..-9 dBFs. ORANGE: -9 dBFs..-3.5 dBFs. RED: > -3.5 dBFs (Overload).
R	Level indicator: OFF: < -78 dBFs (no audio input). GREEN: -78 dBFs..-9 dBFs. ORANGE: -9 dBFs..-3.5 dBFs. RED: > -3.5 dBFs (Overload).

6. Chapter 6

Audio Decoder Card

6.1. Functional description

The audio decoder module allows the reception of audio signals through E1/T1 circuits using different compression formats. All the parameters are configurable by software, even the selection of the analog or digital interface.

6.2. Configuration

The configuration options of the audio decoder module depend on the selected compression algorithm. For each algorithm, there is an option of working as a dual decoder or as two independent decoders. This second option allows the decoding of each received channel using the same algorithm but using different bit rates for each channel.

6.2.1 Decoding algorithms

6.2.1.1 G711:

It allows the reception of audio signals using the standard telephone transmission (3.4 KHz bandwidth). Using G711, each audio channel takes up one time slot of an E1/T1 link (64 Kbps). Each channel in G711 mode can be decoded according to A-Law or μ -Law.

6.2.1.2 G722:

Allows for the reception of a high quality voice signal (7.5 KHz). Using G722, each audio channel takes up one time slot of an E1/T1 link (64 Kbps). Synchronization can be selected between statistical framed (SRT) or H221.

6.2.1.3 MPEG:

Depending on the selected configuration this will change the bandwidth and the delay. Both parameters are explained in the technical specification section. The decoder module allows the following MPEG decoding formats:

- LAYER: II or III
- FREQUENCY: 16, 24, 32 or 48 KHz.
- BITRATE: 64, 128, 192, 256, 320 or 384 Kbps.

- MODE: Stereo, Intensity Stereo, Joint, Dual or Mono.

The allowed sampling frequency, bit rate and mode combinations will depend on the imposed restrictions by the MPEG standard. They are as follows:

		MPEG LAYER II Fs = 48/32 KHz			
		MODE			
		Stereo	Joint Stereo	Dual	Mono
B R A T E	64	X	X	X	X
	128	X	X	X	X
	192	X	X	X	X
	256	X	X	X	
	320	X	X	X	
	384	X	X	X	

		MPEG LAYER II Fs = 24/16 KHz			
		MODE			
		Stereo	Joint Stereo	Dual	Mono
B R A T E	64	X	X	X	X
	128	X	X	X	X
	192				
	256				
	320				
	384				

		MPEG LAYER III Fs = 48/32 KHz			
		MODE			
		Stereo	Joint Stereo	Dual	Mono
B R A T E	64	X	X	X	X
	128	X	X	X	X
	192	X	X	X	X
	256	X	X	X	X
	320	X	X	X	X
	384				

		MPEG LAYER III Fs = 24/16 KHz			
		MODE			
		Stereo	Joint Stereo	Dual	Mono
B R A T E	64	X	X	X	X
	128	X	X	X	X
	192				
	256				
	320				
	384				

It is also possible to enable auxiliary data with the following options:
NO DATA, 300, 1200, 2400, 4800, 9600 or 19200 bps.
Each module has a DB9 connector to transmit auxiliary data.

There is only one auxiliary data channel available per module. However, when working in 2 codecs mode, the auxiliary data can independently be enabled in each codec.

6.2.1.4 J41:

The J.41 standard is recommended for decoding 15KHz mono analog signals for digital transmission at 384Kbit/s. You can use 2 mono digital codecs for stereo. The J.41 standard encoding laws are based on a uniformly quantized 14-bit per sample PCM technique with companding and employ eleven-segment 14- to 11-bit instantaneous A-law companding. There is also a parity bit for error detection. It is calculated from the 5 most significant bits of the sample. For each 2 input samples we get an output code.

There are 2 variants of the standard:

- ❑ Variant, A which is used in units that are based on a hierarchy at 2048Kbit/s (E1).
- ❑ Variant B, which is used in digital units that are based on a digital hierarchy at 1544Kbit/s (T1).

There is an option for setting emphasis on the audio signals according to recommendation J.17. Also the recommendation G.735 for channel (time slot) allocation can be set.

Special compensation mode delays for compatibility with other multiplexers (only for J.41):

In order to be compatible with other manufacturers multiplexers a special mode can be selected that introduces a delay between the two channels. This ensures that the audio channels are phase coherent when connecting a TeamMate unit to other manufacturers multiplexers. The delay offset between L and R channels of a module depends on the assignment of time slots that are selected for each audio channel. This assignment must be made according to the G.735 standard.

- A→ 1,2,3 – 17,18,19 slots.**
- B→ 4,5,6 – 20,21,22 slots.**
- C→ 7,8,9 – 23,24,25 slots.**
- D→ 10,11,12 – 26,27,28 slots.**
- E→ 13,14,15 – 29,30,31 slots.**

Depending the selected group for the L channel, the assignment of time slots for the R channel, should be chosen from the table below:

	A	B	C	D	E
A	X	11.72μS	23.44μS	35.16μS	46.88μS
B	-	X	11.72μS	23.44μS	35.16μS
C	-	-	X	11.72μS	23.44μS
D	-	-	-	X	11.72μS
E	-	-	-	-	X

The time slots that have been assigned to the L channel are in the left column and the slots to be assigned to the R channel are along the top. The values indicate the compensated delay for each combination.

6.2.1.5 J42:

The J.42 standard is recommended for encoding 7KHz mono analog signals for digital transmission 192Kbit/s. The J.42 standard encoding laws are based on a uniformly quantized 14-bit per sample PCM technique with companding and

employ eleven-segment 14- to 11-bit instantaneous A-law companding. There is also a parity bit for error detection. It is calculated from the 7 most significant bits of the sample. For each 2 input samples we get an output code.

There are 2 variants of the standard:

- Variant, A which is used in units that are based on a hierarchy at 2048Kbit/s (E1).
- Variant B, which is used in digital units that are based on a digital hierarchy at 1544Kbit/s (T1).

There is an option for setting emphasis on the audio signals according to recommendation J.17. In the case of the stereo, only one digital channel at 384Kbit/s is used, joining the signals of both channels according to J.41 standard.

6.2.1.6 J57:

The ITU-T J.57 recommendation is used for the transmission of digital sound signals with studio quality by digital hierarchy H11 or H12. The J.57 (H12) standard encoder receives 20bit samples of stereo digital audio at 48KHz. It encodes blocks of 96 audio samples (48 per channel). Giving a 1ms companding block, near instantaneous companding from 20 to 15 bits/sample is applied with 8 coding ranges. Each coded sample has a parity bit (96 parity bits per 1ms companding block) some of these bits are used in order to transmit the scale factor information for each channel, the status of the channel, additional data and MultiFrame Alignment signals (every 1536bits or 192 blocks = 192ms), MFA, and frame slip detection, FSD (in each block of 1 ms). In the case of H12, 3 audio bits and 1 user bit per sample are sent. The H12 level provides a total of 20 bits per sample, and H11 provides a total of 16 bits per sample. To simplify interworking between H11 and H12 channels, the companding of the audio signal is such that the samples are compressed for transmission in the H11 channel. In the H12 channel, extra bits may be conveyed, to improve resolution of the audio coding and provide a user data channel. H11 uses 24 time slots and H12 30 at 64 Kbps.

6.2.1.7 apt-X™: Standard & Enhanced

**This option is not available in the standard version.
For more information, contact support@musicamusa.com**

It allows the reception of audio with similar quality to linear PCM but at a much reduced bit-rate. apt-X™ is a low complexity audio compression algorithm offering unsurpassed audio quality, it is robust to random bits errors, extremely tolerant to tandem coding and has short coding delay. The apt-X™ system is based on an implementation of subband Adaptive Differential Pulse Code Modulation, (Subband ADPCM). The Standard apt-X™ transparently code 16-bit PCM audio with a fixed compression ratio of 4:1. Also, there are three improved versions, Enhanced apt-X™, offering further levels of operation with a choice of 16, 20 or 24 bit resolution. These Enhanced versions deliver a significant improvement in audio an processing delay performance coupled with faster synchronization and a new method for embedding auxiliary data.

Depending on the selected algorithm (Standard or Enhanced) and sampling frequency the delay will change. The bandwidth depends just on sampling frequency. Both parameters are explained in the technical specification section. The decoder module allows the following apt-X™ decoding formats:

- Standard, Enhanced 16 bits, Enhanced 20 bits or Enhanced 24 bits apt-X™.
- FREQUENCY: 16, 32 or 48 KHz.
- BITRATE: 64, 128, 192, 256, 320, 384 or 576 Kbps.
- MODE: Mono or Stereo.

The bit rate depends on the number of audio channels, sampling frequency and apt-X™ algorithm. They are as follows:

FREQUENCY	MODE	apt-X Standard	apt-X Enhanced		
			16 bits	20 bits	24 bits
16 kHz	mono	64 kbps	64 kbps	-	-
16 kHz	stereo	128 kbps	128 kbps	-	192 kbps
32 kHz	mono	128 kbps	128 kbps	-	192 kbps
32 kHz	stereo	256 kbps	256 kbps	320 kbps	384 kbps
48 kHz	mono	192 kbps	192 kbps	-	-
48 kHz	stereo	384 kbps	384 kbps	-	576 kbps

Note: modes marked with "-" are not allowed, because they have bit rates not multiple of 64 kbps.

It is also possible to enable auxiliary data with the following options:
NO DATA, 300, 1200, 2400, 4800, 9600 or 19200 bps.
Each module has a DB9 connector to transmit auxiliary data.

There is only one auxiliary data channel available per module.

6.2.2 Selecting the audio output

The audio output can be selected between analog or digital.

6.2.3 Gain adjustment:

The gain of each channel can be adjusted between +6 –6 dB in steps of 1dB.

6.2.4 Activating the test tone:

The test tone of 1004 Hz and –12 dBFs can be activated or deactivated in each channel without being affected by the gain control. If the decoder is framed, its level will be reflected in the VU meters replacing the decoded audio.

6.3. Monitoring

6.3.1 LEDs

There are three LED's in the front of each module:

AN/DIG	ON: shows the selected analog output. OFF: shows the selected AES/EBU output.
L/SYNC	Framed audio LED: OFF: Decoder not framed. ON: Decoder framed. The color of the LED will vary depending on the output audio level: Green: less than –9 dBFs. Orange: from -9dBFs to –3.5 dBFs Red: more than –3.5 dBFs, overhead.
R/SYNC	Framed audio LED: OFF: Decoder not framed. ON: Decoder framed. The color of the LED will vary depending on the output audio level: Green: less than –9 dBFs. Orange: from -9dBFs to –3.5 dBFs Red: more than –3.5 dBFs, overhead

7. Chapter 7

Synchronous data card

7.1. Functional Description

The Data Card is able to manage up to two independent bi-directional lines of synchronous data, each one at a speed selectable between 64 kbps and 1984 kbps. The way these data lines are multiplexed across the E1/T1 time slots is totally configurable, allowing great flexibility in the assignment of available resources.

The features of each one of these data lines are as follows:

- V-35/X21 Interface with high-density connectors SCSI-20 (Micro-D).
- Working as DCE or DTE.
- Bi-directional data line, with the same Tx and Rx speed.
- Transparent synchronous data line.
- Selectable speed of $n \times 64$ kbps, from 64 kbps up to 1984 kbps, with option of deactivating the hand shaking lines (TD, CTS, DSR or DCD).
- Reception from any E1/T1 channel.
- Transmission/distribution to any E1/T1 channel.

The sum of speeds of the two data lines must not exceed 2048 kbps; otherwise only one of them will work.

7.2. Configuration

7.2.1 Installing the physical drivers

The drivers are on daughter boards that are fitted on the module main board. These have the required interface circuitry to translate X21/V35 voltage levels to the internal TTL levels. The position of the card determines whether the data module works as DTE (data terminal equipment) or as DCE (data circuit equipment). Each data connector has a driver card and you must follow the following steps in order to install them:

1. Using normal anti-static precautions, the data module must not be powered.
2. Position the driver card to match the annotation on the data module:
For DTE with the letter T ("Terminal") nearest to the connector or as DCE with the letter M ("Modem") nearest the connector.
3. Install the driver card nearest to the connector which you intend to use.

If a connector is not going to be used, it is not necessary that it has the driver card installed.

The orientation of the driver card determines if the data channel works as DTE or as DCE.

7.2.2 Speed selection

The speed of each data channel can be configured between 64 kbps and 1984 kbps (31x64 kbps), in intervals of 64 kbps. The default configured speed is 0.

7.2.3 Control signals (Handshaking)

The V35 interface incorporates control signals that are used by the communications protocol. These signals can be used to detect the status of the line by monitoring the relevant signals. In the case of DCE operation, the DTR and/or RTS signals will be able to be used in order to determine the status of the line. When the Data module detects the line drop, it ignores the received data and transmits binary zero data through the E1/T1 time slots. Transmission from the module to the data line is not affected.

There is an option of disabling the monitoring of these signals (HANDSHAKING NONE). If this is set, and the Data module is not connected random data will be transmitted through the corresponding E1/T1 time slots.

The default configuration is that the status of the line is only detected by the DTR signal (or DSR if the card works as DTE).

If you specify speed 0, CTS, DSR and DCD (RTS and DTR if it is DTE) will be deactivated.

7.3. Monitoring

7.3.1 LEDs

Under normal working, the data card has three leds to indicate its status

LED S	Card status
LED L1	Line 1 status
LED L2	Line 2 status

7.3.1.1.a Card state

Once the module is operational, the LED S will show steady green.

7.3.1.1.b Line state

The LED L1 reflects the line state of the LINE 1 connector, and the LED L2, the state of the LINE 2 connector. The following table presents the possible line states according to the color.

LED color	Line state
OFF	Not active. Speed 0 has been configured.
RED	Not active. The reason could be the line has dropped; the sum of the configured time slots is over the allowed maximum, or a temporary state.
YELLOW	Active. Some of the control signals are not active: DSR, DCD and CTS in DTE mode, and DTR and RTS in DCE mode.
GREEN	Active.

8. Chapter 8 Power Supply

The TeamMate accepts the installation of a AC or DC (48VDC) power supply. In addition, it is possible to install in each subrack a second secondary power supply to come into operation in case of failure of the main power supply.

For each type of power supply, there is a different power supply module and either of them can work as main or secondary power supply.

The main power supply must always be installed in the CN1 connector of the subrack and the secondary power supply in the CN2 connector.

The power supply requires the installation of a jumper when working as main PS.

Please, before installing a power supply, always verify that the jumper is correctly configured depending on the use of the PS (main or secondary).

Jumper P1

- ***Main power supply:***

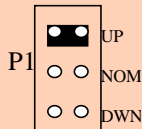

- ***Secondary power supply:***

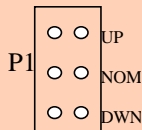

8.1.1 Block Diagram of the power supply modules:

Both types of power supply (AC or DC) work the same way with the exception of their input circuit which changes due to that each one of them admit a different type of supply (AC or DC).

The power supplies give two types of supply to the TeamMate:

- +52 VDC / +48 VDC. When the power supply works as main PS, it supplies +52 volts. When working as secondary PS, the voltage is +48 volts. The P jumper is installed to configure the operation mode so that the power supply will work as main PS.
- +5 VDC. This voltage is obtained and independent from the 48 volts of the backpanel (or 52 volts when working as main power supply) generated in the module itself.

Moreover, it is possible to monitor both voltages remotely from the control module having each supply module the necessary devices to carry out this monitoring.

As shown in the following diagram, the control module gives information on the voltage supplied by the power supply module as well as on the voltage available in the backpanel.

There are two LEDs in the front panel of each power supply showing the state of the voltages generated by the module itself.

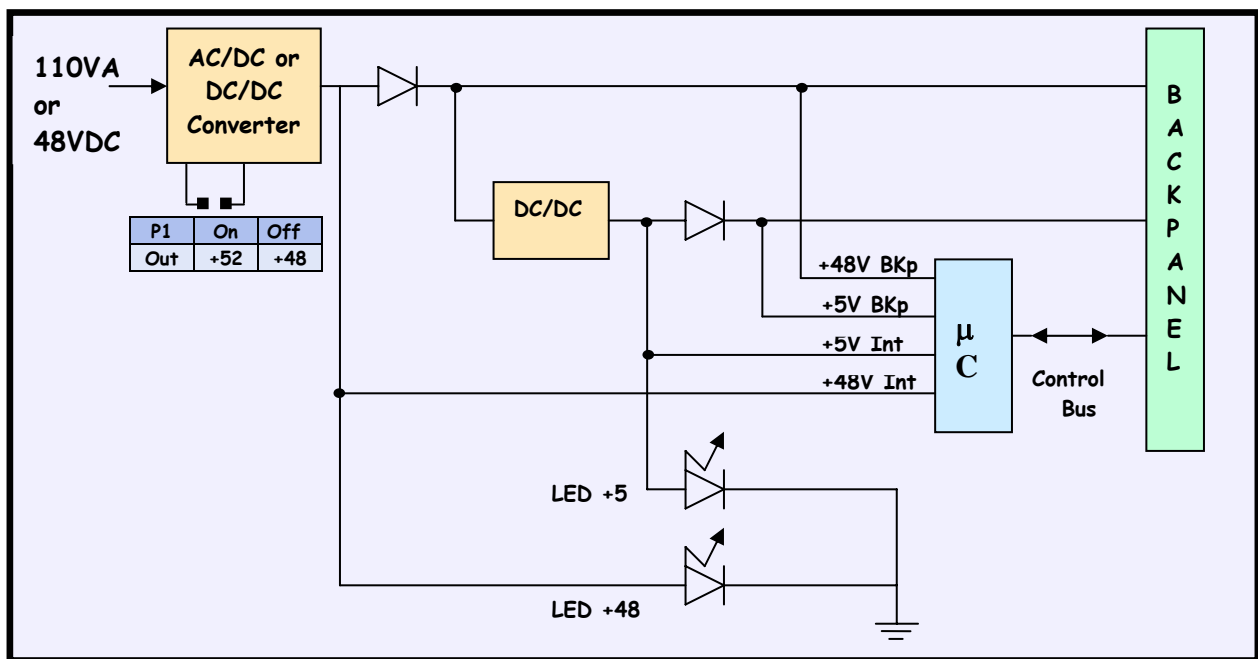

9. Chapter 9 Expansion Module

If the number of audio or data modules needs to be extended, it is necessary to install extension modules to allow the connection of additional racks.

The extension modules occupy fixed positions within each subrack. An extension module will be inserted in slot 15 of the main subrack and in slots 0 and 15 of the following subracks. The connection between subracks will be carried out with a standard 50 ways SCSI cable. This cable is supplied together with the units, if requested according to the configuration inquired by the user.

The extension boards have programming bridges which configuration will depend on the subrack it will be installed and the slot to be inserted in. Following is a table with this configuration:

Jumpers configuration of the Extension board				
Subrack	Slot	Jumper P1	Jumper P2	Jumper P3
0 (Main Subrack)	15	OPEN	OPEN	OPEN
1,3,5,7	15	CLOSED	CLOSED	OPEN
1,3,5,7 (If it is the last subrack)	0	OPEN	OPEN	CLOSED
1,3,5,7 (If it is not the last subrack)	0	OPEN	OPEN	OPEN
2,4,6,8	0	CLOSED	OPEN	OPEN
2,4,6,8	15	OPEN	OPEN	OPEN

10. Appendix A

Technical specifications

10.1. E1/T1 Module

10.1.1 E1 - Tx:

- Interface: According to G.703 recommendation
- Line speed: ± 50 ppm (internal clock).
- Connectors: BNC Coax. 75Ω / RJ45 120Ω 22AWG (0.6 mm).
- Line code: HDB3 (High Density Bipolar of order 3 code).
- Protection: Isolated output for transformer.
- Jitter: ETS 300 011 and TBR12.

10.1.2 E1 - Rx:

- Interface: According to G.703 recommendation.
- Line speed: 2048 Kbps.
- Connectors: BNC Coax. 75Ω / RJ45 twisted pair 120Ω 22AWG (0.6 mm).
- Line code: HDB3.
- Protection: Isolated input for transformer
- Tolerance to Jitter: according to ITU G.823.

10.1.3 T1 - Tx :

- Interface: According to G.703 recommendation.
- Line speed: 1544 Kbps ± 50 ppm (internal clock).
- Adaptation to the shape of wave: DSX-1 (*short haul*) 0 at 655 ft / DS-1 (*long haul*) 0 dB at -22.5 dB.
- Connector: RJ45 twisted pair 100Ω .
- Line codes: B8ZS (bipolar with replacement of eight zeros) and AMI.
- Framed: D4/ESF.

- Protection: Isolated output for transformer.
- Jitter: TR 62411.

10.1.4 T1 – Rx:

- Interface: According to G.703 recommendation.
- Line speed: 1544 Kbps.
- Connectors: RJ45 twisted pair 100Ω.
- Line codes: B8ZS/AMI.
- Framed: D4/ESF.
- Protection: Isolated input for transformer.
- Tolerance to Jitter: according to TR 62411.

10.2. Audio Encoder Module

10.2.1 Stereo audio input:

Balanced analog input:

Maximum input level +22 dBu.

Input impedance 20K Ω .

Balanced digital input:

AES/EBU format: EIAJ CP-340 type I/IEC-958 Pro

Sampling rate converter: 1:3 to 3:1.

10.2.2 Audio properties:

Quantization: 24 bits A/D converter.

S/N ratio > 95 dB typical.

Crosstalk > 80 dB

Phase difference < 0.3 $^{\circ}$

10.2.3 Compression:

- G711:
 - μ -Law and A-Law.
 - Two channels per module.
- G722:
 - Two channels per module.
- MPEG Layer II / III:
 - One stereo channel or two mono channels.
 - Bit rates: 64, 128, 192, 256, 320 or 384 Kbps.
 - Fs = 48, 32, 24 or 16 KHz.
 - Modes = Mono, Dual, Joint Stereo or Stereo.
- J41:
 - 2 channels per encoder module.
 - 15 KHz bandwidth.
 - Option to activate or de-activate pre-emphasis according to standard J17.
- J42:
 - 2 channels per encoder module.
 - 7.5 KHz bandwidth.
 - Option to activate or de-activate pre-emphasis according to standard J17.
- J57:

- 1 stereo channel per encoder module.
 - 24 KHz (@ 48KHz Fs) bandwidth.
 - H11 or H12.
- apt-X™:
- One channel per module.
 - Standard, Enhanced 16 bits, Enhanced 20 bits or Enhanced 24 bits apt-X™.
 - Bit rates: 64, 128, 192, 256, 320, 384 or 576 Kbps.
 - Fs: 48, 32, or 16 KHz.
 - Modes: Mono or Stereo.

10.2.4 BANDWIDTH MPEG LAYER II

Fs	Bit Rate	BANDWIDTH (KHz)		
		MONO	JOINT STEREO	DUAL/STEREO
16 KHz	64 Kbps	7.5	7.5	7.25
	128 Kbps	7.5	7.5	7.5
24 KHz	64 Kbps	11.25	11.25	7.125
	128 Kbps	11.25	11.25	11.25
32 KHz	64 Kbps	11.5	6.0	5.0
	128 Kbps	15.0	13.5	11.5
	192 Kbps	15.0	15.0	15.0
	256 Kbps	-	15.0	15.0
	320 Kbps	-	15.0	15.0
	384 Kbps	-	15.0	15.0
48 KHz	64 Kbps	10.5	5.25	4.5
	128 Kbps	20.0	15.75	10.5
	192 Kbps	20.0	20.0	13.5
	256 Kbps	-	20.0	20.0
	320 Kbps	-	20.0	20.0
	384 Kbps	-	20.0	20.0

10.2.5 BANDWIDTH MPEG LAYER III

Fs	Bit Rate	BANDWIDTH (KHz)	
		MONO	DUAL/JOINT STEREO/STEREO
16 KHz	64 Kbps	7.5	7.5
	128 Kbps	7.5	7.5
24 KHz	64 Kbps	10.0	8.0
	128 Kbps	11.3	11.3
32 KHz	64 Kbps	15.0	8.0
	128 Kbps	15.0	15.0
	192 Kbps	15.0	15.0
	256 Kbps	15.0	15.0
	320 Kbps	15.0	15.0
48 KHz	64 Kbps	15.0	8.0
	128 Kbps	18.0	18.0
	192 Kbps	20.0	20.0
	256 Kbps	20.0	20.0
	320 Kbps	20.0	20.0

10.2.6 BANDWIDTH apt-X™

Fs	BANDWIDTH (KHz)
16 KHz	7.5
32 KHz	15
48 KHz	20

10.3. AUDIO DECODER MODULE

10.3.1 Stereo audio output:

Balanced analog output:

Maximum output level +22 dBu.

Output impedance 50Ω.

Balanced digital output:

AES/EBU format: EIAJ CP-340 type I/IEC-958 Pro

Sampling rate converter: 1:3 to 3:1.

10.3.2 Audio properties:

Quantization: 24 bits D/A converter.

S/N ratio > 95 dB typical.

Crosstalk > 80 dB

Phase difference < 0.3°

10.3.3 Compression:

- G711:
 - μ -Law and A-Law.
 - Two channels per module.
- G722:
 - Two channels per module.
- MPEG Layer II / III:
 - One stereo channel per module or two mono.
 - Bit rates: 64, 128, 192, 256, 320 or 384 Kbps.
 - Fs = 48, 32, 24 or 16 KHz.
 - Modes = Mono, Dual, Joint Stereo or Stereo.
- J41:
 - 2 channels per decoder module.
 - 15 KHz bandwidth.
 - Option to activate or de-activate De-emphasis according to standard J17.
- J42:
 - 2 channels per decoder module.
 - 7.5 KHz bandwidth.
 - Option to activate or de-activate De-emphasis according to standard J17.
- J57:
 - 1 stereo channel per decoder module.
 - 24 KHz (@ 48KHz Fs) bandwidth.
 - H11 or H12.
- apt-X™:
 - One channel per module.
 - Standard, Enhanced 16 bits, Enhanced 20 bits or Enhanced 24 bits apt-X™.
 - Bit rates: 64, 128, 192, 256, 320, 384 or 576 Kbps.
 - Fs: 48, 32, or 16 KHz.
 - Modes: Mono or Stereo.

10.3.4 Delays

ENCODING MODE	Fs	BIT RATE	Delay (ms)
G711	8 KHz	64 Kbps	8
G722	16 KHz	64 Kbps	7.6
J41 (No emphasis)	32 KHz	384 Kbps	4
J42 (MONO)	16 KHz	192 Kbps	6
J42 (STEREO)	16 KHz	384 Kbps	6
J57-H11	48 KHz	1536 Kbps	6
J57-H12	48 KHz	1920 Kbps	6
MPEG LAYER II	16 KHz	All	280
	24 KHz	All	196
	32 KHz	All	154
	48 KHz	All	110
MPEG LAYER III	16 KHz	64 Kbps	334
		128 Kbps	300
	24 KHz	64 Kbps	258
		128 Kbps	208
	32 KHz	64 Kbps	Mono:344 Stereo,Dual:380
		128 Kbps	270
		192 Kbps	270
		256 Kbps	234
		320 Kbps	234
	48 KHz	64 Kbps	Mono:280 Stereo,Dual:308
		128 Kbps	212
		192 Kbps	186
256 Kbps		164	
320 Kbps		166	
STANDARD apt-X™	16 KHz	64 Kbps	14.8
		128 Kbps	14.8
	32 KHz	64 Kbps	8.4
		128 Kbps	8.4
	48 KHz	64 Kbps	5.2
		128 Kbps	5.2
ENHANCED 16 BITS apt-X™	16 KHz	64 Kbps	12.9
		128 Kbps	12.9
	32 KHz	64 Kbps	7.6
		128 Kbps	7.6
	48 KHz	64 Kbps	4.4
		128 Kbps	4.4
ENHANCED 20 BITS apt-X™	32 KHz	320 Kbps	7.6
ENHANCED 24 BITS apt-X™	16 KHz	192 Kbps	12.9
	32 KHz	192 Kbps	7.6
		384 Kbps	7.6
48 KHz	576 Kbps	4.4	

These values are the total delay (Encode and Decode).

10.4. Synchronous data module

10.4.1 Speed

From 0 to 1984 Kbps on E1 channels in steps of 64 Kbps.
From 0 to 1536 Kbps on T1 channels in steps of 64 Kbps.

10.4.2 Data format

Transparent data without restriction.

10.4.3 Interface

V35 or X21. Configurable as DCE or DTE according to installation of the driver card.

10.4.4 Supported signals in the interface V35

DTR, RTS, DSR, DCD.

10.4.5 Connector

High-density connectors SCSI-20 (Micro-D) for each data port.

10.5. Power

10.5.1 AC Power Supply:

Nominal input: 115 Vac
Input range: 100-120 Vac
Fuse: 3A
Output power: 200 Watt max

10.5.2 DC Power Supply:

Nominal input: 48 VDC
Input range: -36..-72 VDC
Fuse: 8A
Output power: 200 Watt max

10.6. Environmental

Operating Temperature: 0 to +50 °C
Humidity: 10 to 90% non-condensing.

10.7. Physical

10.7.1 Size

Rack: Height:4U ; Width:19" ; Depth:14.6".

AC Power supply Module: = 2"

DC Power Supply Module: = 2"

E1/T1 Module: = 0.8"

Control Module: = 0.8"

Audio Encoder Module: = 1.6"

Slim Audio Encoder Module: = 0.8"

Audio Decoder Module: = 1.6"

Slim Audio Decoder Module: = 0.8"

Data Module: = 0.8"

Expansion Module: = 0.8"

11. Appendix B Connectors

11.1. E1/T1 Module

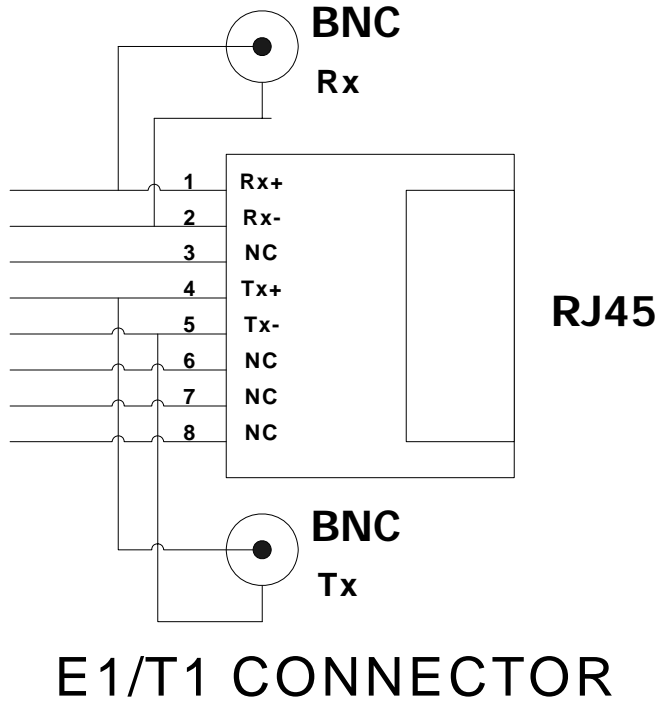

11.2. Control Module

11.2.1 Console connector

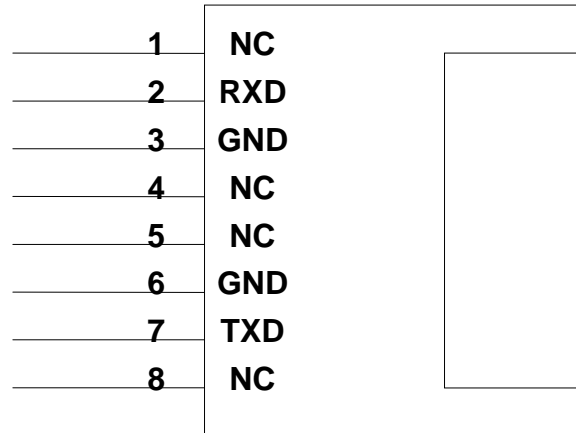

11.2.2 GPO Connector

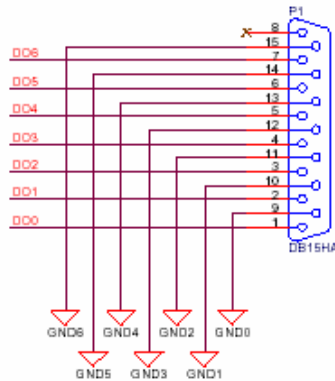

PIN	SIGNAL	PIN	SIGNAL
1	Output 1	9	GND1
2	Output 2	10	GND2
3	Output 3	11	GND3
4	Output 4	12	GND4
5	Output 5	13	GND5
6	Output 6	14	GND6
7	Output 7	15	GND7

Technical specifications

I_{cmax} = 50 mA.

V_{cemax} = 70 V ; V_{ecmax} = 7 V.

P_{max} = 150 mW.

11.3. Audio Encoder Module

11.3.1 Audio XLR Connector:

PIN	SIGNAL
1	GND
2	+
3	-

11.3.2 Audio DB9 Connector:

PIN	SIGNAL
1	R+ (analog input) / AES-EBU input +
6	R - (analog input) / AES-EBU input -
2,3,4	GND
5	L+ (analog input)
9	L - (analog input)

11.3.3 Auxiliary data connector:

PIN	SIGNAL	PIN	SIGNAL
1	NC	6	NC
2	Tx	7	NC
3	NC	8	NC
4	NC	9	NC
5	GND		

11.4. Audio Encoder Module with two audio connectors

11.4.1 AES/EBU:

PIN	SIGNAL
1	AES-EBU input +
6	AES-EBU input -
2,3,4	GND
5,9	NC

11.4.2 Analog Audio:

PIN	SIGNAL
1	R+ (analog input)
6	R - (analog input)
2,3,4	GND
5	L+ (analog input)
9	L - (analog input)

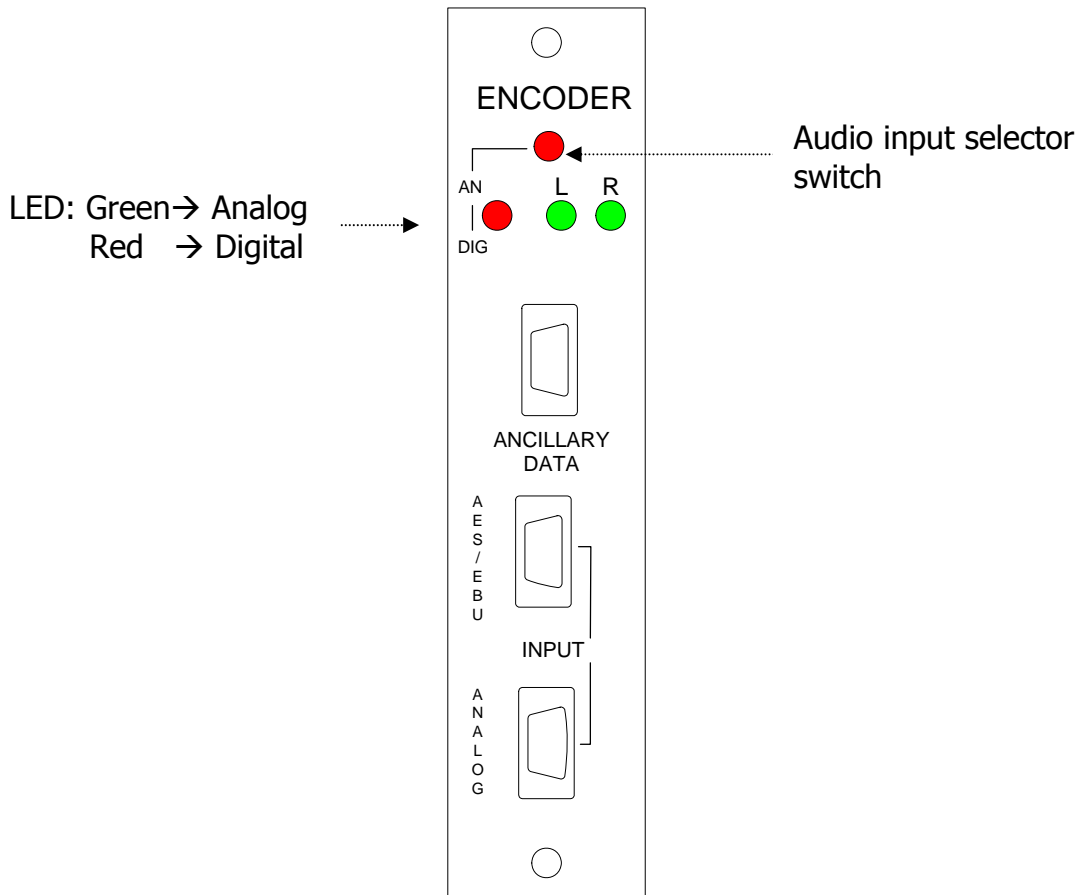

11.5. Audio Decoder Module

11.5.1 Audio XLR connector:

PIN	SIGNAL
1	GND
2	+
3	-

11.5.2 Audio DB9 Connector:

PIN	SIGNAL
1	R+ (analog output) / AES-EBU Sync input +
6	R - (analog output) / AES-EBU Sync input -
2,3,4	GND
5	L+ (analog output) / AES-EBU output +
9	L - (analog output) / AES-EBU output -

11.5.3 Auxiliary data connector:

PIN	SIGNAL	PIN	SIGNAL
1	NC	6	NC
2	NC	7	NC
3	Rx	8	NC
4	NC	9	NC
5	GND		

11.6. Decoder module with two connectors

11.6.1 AES/EBU:

PIN	SIGNAL
1	AES-EBU Sync input +
6	AES-EBU Sync input -
2,3,4	GND
5	AES-EBU output +
9	AES-EBU output -

11.6.2 Analog Audio:

PIN	SIGNAL
1	R+ (analog output)
6	R - (analog output)
2,3,4	GND
5	L+ (analog output)
9	L - (analog output)

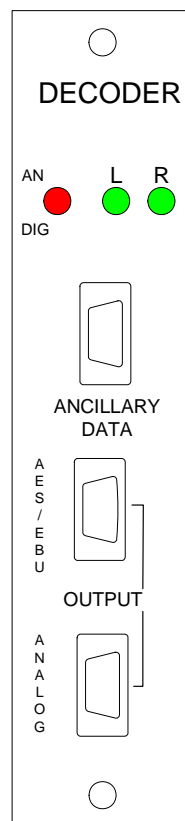

11.7. Data Module

11.7.1 Data Connector

SIGNAL	Harting SCSI 20M CONNECTOR	V.35 SIGNAL
TD+	1	S
TC- (Tx CLOCK -)	2	Y
RD+	3	T
RC- (Rx CLOCK -)	4	V
TC+ (Tx CLOCK +)	5	AA
RC+ (Rx CLOCK +)	6	X
DTR	7	H
ETC-	8	U
TD-	11	P
RD-	12	R
RTS	13	C
CTS	14	D
DSR	15	E
GND	16	B
CD	17	F
ETC+	18	W
GROUND	20	A

11.7.2 Cable description (SCSI-DB25)

SIGNAL	Harting SCSI 20M CONNECTOR	V.35 SIGNAL	DB25 CONNECTOR
TD+	1	S	14
TC-	2	Y	15
RD+	3	T	16
RC-	4	V	17
TC+	5	AA	18
RC+	6	X	19
DTR	7	H	20
ETC-	8	U	24
TD-	11	P	2
RD-	12	R	3
RTS	13	C	4
CTS	14	D	5
DSR	15	E	6
GND	16	B	7
CD-	17	F	8
ETC+	18	W	9
GROUND	20	A	1