

Advanced Codec Configurations and Applications

Going beyond the basics to meet the needs of your special applications

3. Advanced Configurations for Custom Applications

Although there are well over two dozen Quick Configurations pre-loaded into your **CDQPrima**, there may be some applications that require special encoder and decoder settings. For example, you may want to send two different audio programs to different locations, or you may want to send the same program to several locations. Other examples may be sending high quality audio to a recording studio but receiving low delay return audio for cueing. Another type of special applications includes automatic switching and control based on codec status. These later applications will be described in the Prima Logic Language chapter of this manual.

These and other special configurations and applications will be described in this chapter, along with step-by-step instructions. Most custom application will require the decoder section to operate independently of the encoder. Once your special application has been set up, you can instantly save the configuration for later recall.

3.1 Decoder Independent Mode

Normal mode of operation is to slave the decoder to the encoder, which means that all decoder bit rate, algorithm and line format settings are the same as the encoder settings. The decoder algorithm mode (mono, joint stereo, stereo) and sample rate will always slave to the incoming signal once frame is established. Making the decoder dependent on the encoder makes it simpler to configure the **CDQPrima** since only the encoder parameters need to be set.

There are instances where it may be necessary to operate in the decoder independent mode. **The broadcast and dual channel modes described in this chapter require the decoder to be independent, as do connections to codecs made by other manufacturers.** Another instance where the decoder must be independent is if the return audio is not using the same encoding algorithm as the send audio. It is also possible to receive audio from one location and send audio to another location. It may be desirable, and it is possible, to send high quality MUSICAM audio, but for the return audio to be low delay-time G.722 audio.

When the decoder is set to independent, all encoder and decoder parameters must be set independently, since the decoder settings are not linked to the encoder settings.

3.2 Broadcast Applications

The first class of custom applications falls into the “broadcast” category, that is, delivering the same audio program to many locations. With *no* external hardware, your 200 Series **CDQPrima** can deliver monaural audio to up to six locations, or stereo audio to three. If external terminal adapters are used, up to six locations can be sent the same stereo program. This is an ideal application for dial-in services, where users dial at specific times to get program delivery. Another broadcast application is radio stations using multiple transmitter sites.

3.2.1 Monaural Audio to Six Locations

Figure 3-1 shows an application where up to six locations are receiving the same monaural audio from the same source simultaneously.

Application
Note #1

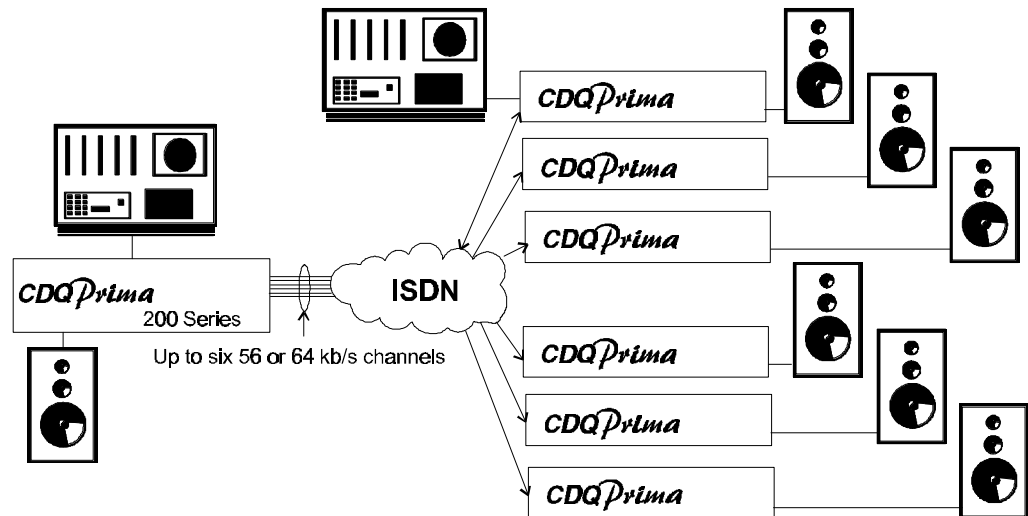

Figure 3-1 Monaural broadcast to 6 locations

Using either internal or external ISDN terminal adapters, or external CSU/DSUs for dedicated links, it is possible to broadcast to six locations simultaneously. You can monitor the return audio from any one of the six remote locations, switching between the locations at any time. You can even combine ISDN and dedicated links using appropriate interface cards. Each terminal adapter or DIF allows 2 users to be connected. Here's how to do it:

- Set your local **CDQPrima** encoder (any 200 Series model) to 56 or 64 kb/s, mono, single line mode, line 1. The lowest bit rate of any location determines the bit rate for all locations. For example, if five locations are serviced by ISDN, but one location only has Switched-56 service, than all locations must use 56 kb/s.
- The algorithm and sample rate you choose depend on the frequency response required and the type of codecs at the remote locations. You can use G.722, MPEG Layer II or **MPEG Layer III** at any valid sampling rate that can be used with all attached locations. Refer to Chapter 6 in the **CDQPrima** Users Guide for algorithm comparisons.
- **Set your local CDQPrima decoder to independent**, and to the same bit rate as the encoder. The decoder line format should be 1-line. The line you select will be the return audio you will monitor, and you can change it at any time.

Rev. 6

- Set all remote codecs to single line mode, the algorithm, bit rate and sample rate should match your local **CDQPrima** settings. All remote locations must use the same settings.
- The broadcast codec does not have to be framed to be sending audio to all location. The codec will not be framed if the decoder line selected is not connected.

If you want to broadcast the audio from one remote location to all other locations, simply set the decoder to the desired line, and loop the **CDQPrima**'s audio output to the audio input, either digital or analog.

Application
Note #2

3.2.2 Stereo Audio to Three Locations

Stereo broadcasting to three independent locations is possible using internal or external terminal adapters, as shown in figure 3-2. In addition, the stereo return audio can be monitored from any one of the three remote locations. This method, using CCS 2-line mode, does not require you to use the same terminal adapter, either internal or external, at all locations. As long as all codecs and terminal adapters are compatible with the **CDQPrima**'s 2-line mode of operation, they can be used in this configuration. In this configuration, you can combine ISDN and dedicated lines only if external terminal adapters are used.

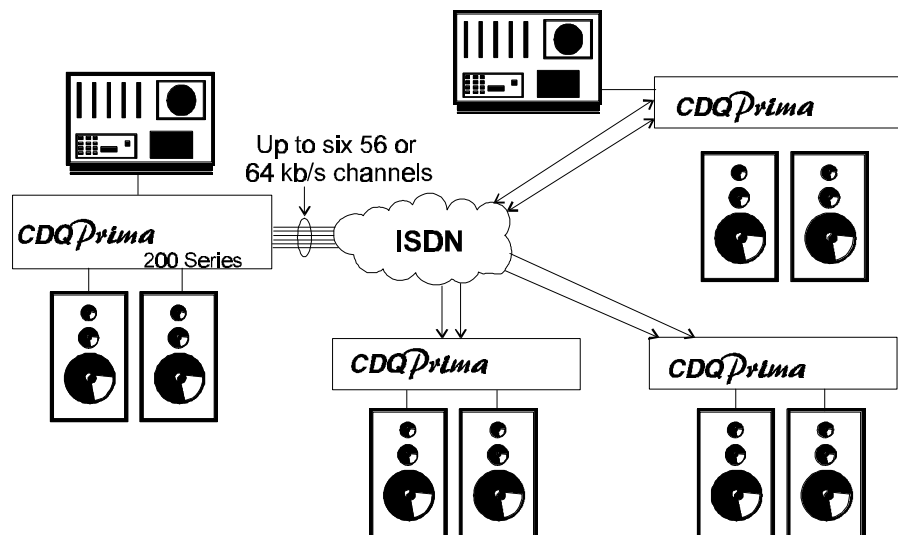

Figure 3-2 Stereo broadcast using internal terminal adapters

- At the local **CDQPrima**, set the encoder to 112 or 128 kb/s, joint stereo, stereo, or dual mono, MPEG Layer II or III, and set the desired sampling rate. Refer to Chapter 6 of the **CDQPrima Users**

Rev. 6

Guide for comparisons of the various formats. The lowest bit rate of any location determined the bit rate for all locations. For example if two locations have 64 kb/s ISDN but one location only has 56 kb/s service, then all locations must use 112 kb/s.

- Set the encoder line format to 2-lines, and select lines 1 and 4 if going to three locations, or lines 1 and 3 if going to two.
- **Set the local decoder to independent**, and the same bit rate and sampling rate as the encoder. To monitor return audio from the first remote location (when configured for three), set the decoder line format to 2-lines, lines 1 and 4. To monitor return audio from the second remote location, select lines 2 and 5. To monitor the return audio from the third remote location, select lines 3 and 6. The lines can be switched at any time to toggle the return audio between locations. When connecting to two locations, set the decoder lines format to 2-lines, lines 1 and 3 for the first location and lines 2 and 4 for the second.
- Dial all locations, using lines 1 and 4 for the first location (assuming three), lines 2 and 5 for the second location, and lines 3 and 6 for the third location. When only 2 locations are used, dial the first on lines 1 and 3, and use lines 2 and 4 for the second.
- The remote codecs should be configured to match the bit rate, sample rate, algorithm, and algorithm mode of the local **CDQPrima**. The line format should be 2-line.
- The broadcast codec does not have to be framed to be sending audio to all location. The codec will not be framed if the decoder lines selected are not connected.

Application Note #3

3.2.3 Stereo Broadcasting to Six Locations

It is also possible to broadcast 20 kHz stereo, at *any* desired bit rate from 112 to 384 kb/s, to up to six locations if appropriate external terminal adapters or CSU/DSUs are used at all locations. You can even mix ISDN with other digital transmission systems, using the appropriate external adapters. This is shown in Figure 3-3. For bit rates of 128 kb/s or higher, all terminal adapters must support internal BONDING and must be compatible with each other.

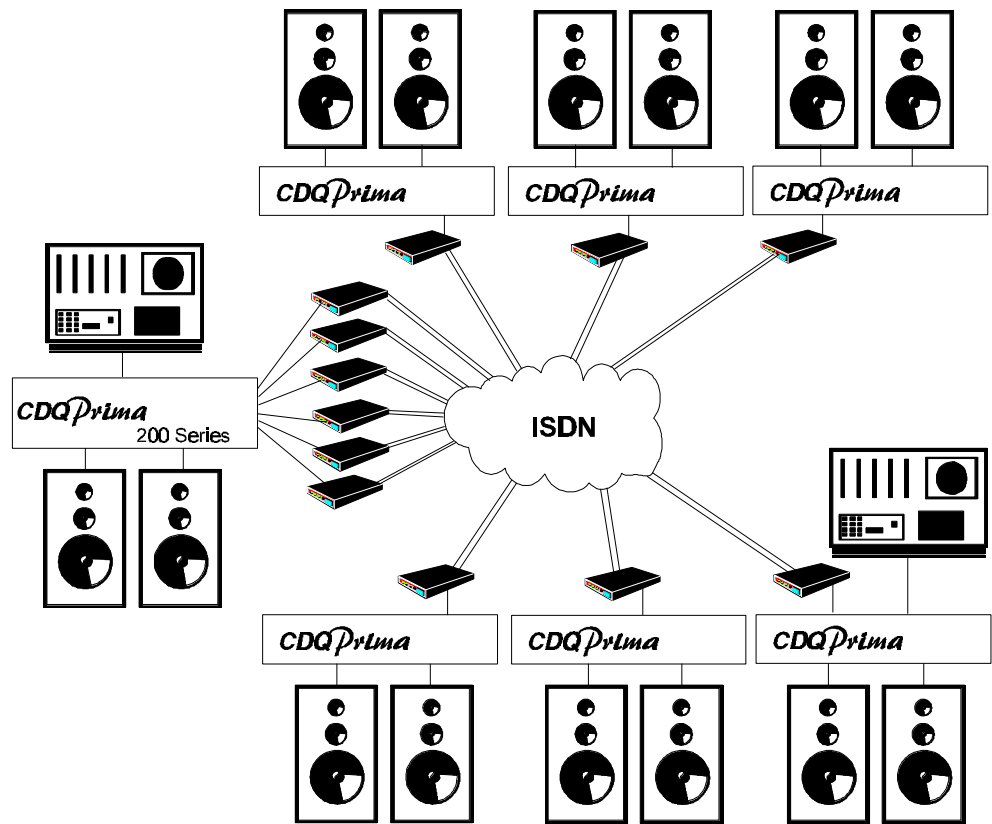

Figure 3-3 Stereo broadcast to six locations using external terminal adapters

- Set the local **CDQPrima** to the desired bit rate, algorithm, algorithm mode and sample rate. Higher bit rates are possible using more ISDN lines and an appropriate terminal adapter.
- Set the encoder line format to 1-line, selecting line 1.
- Using an appropriate cable, connect each digital interface port on the **CDQPrima** to an external terminal adapter capable of 2 (or more) line operation, CSU/DSU, or other appropriate interface.
- Set the local decoder to independent, and select the same bit rate and sampling rate as the encoder. Select 1-line format. The line you select determines which remote **CDQPrima** you will monitor, and can be changed at any time.
- Dial all locations from the external terminal adapters. Each location requires that two (or more) ISDN 'B' channels be dialed.

Please check our web page at www.musicamusa.com for additional application notes

- The remote codecs and terminal adapters should be configured to match the settings of the local **CDQPrima** and terminal adapters.

3.3 Dual Algorithm Applications

The **CDQPrima** is ideal for applications where different algorithms for send and receive audio must be used. For example, a voice talent wishes to use the best possible algorithm during a session with a recording studio, but also wishes that the return audio have the lowest delay possible. Using MUSICAM at 128 kb/s mono for send audio and G.722 at 64 kb/s for return.

Here's how the announcer's **CDQPrima** is set:

- The encoder is set to 128 kb/s, MPEG2, mono, 48 kHz sampling, CCS2LINE, lines 1 and 2. You can use Quick-Configuration 35 for this.
- **The decoder is set to independent YES**, 1 Line, line 1, 64 kb/s, G.722.

Here's how the studio **CDQPrima** is set:

- The encoder is set to 64 kb/s, G.722, 1 Line, line 1. Note: setting the algorithm to G.722 automatically sets the sample rate and algorithm mode.
- **The decoder is set to independent YES**, CCS2LINE, lines 1 and 2, 128 kb/s, MPEG2.

In this example, both lines must be connected for best send audio. Other algorithm combinations are also possible. Indeed, any supported algorithms can be combined in a dual algorithm mode. An another useful combination is 64 kb/s Layer III send with G.722 return.

3.4 Independent Mono / Dual G.722 Operation

Rev. 6

A single *CDQPrima* can now send two *different* monaural audio channels to two (or more) locations as shown in Figure 3-4. It is also possible to receive return audio from these locations.

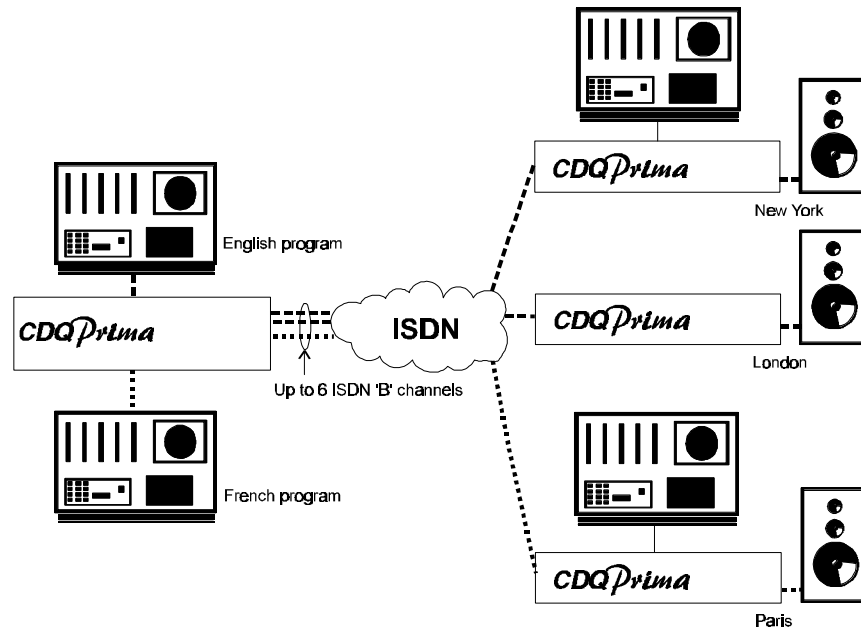

Figure 3-4 Independent Mono Capabilities

Independent mono capabilities allow the *CDQPrima* to be used as two independent MPEG Layer II or G.722 encoders, enabling you to send different audio to different locations. Combined with the broadcasting capabilities of the *CDQPrima*, Independent Mono can be used to send audio input to the left channel to one (or more) locations while sending audio input to the right channel to other locations. If the head end is any 200 Series *CDQPrima*, any combination of locations, up to a total of 6 can be supported. Only two locations can be supported with a 100 Series *CDQPrima*. For example, the English program can be sent simultaneously to New York, London and New Zealand while the French program can be sent to Paris and Quebec.

If G.722 is used for the return audio, two locations can be monitored simultaneously. With MPEG Layer II, only one location can be monitored, but you can instantly switch between locations. Here's how to do it:

- Set the local *CDQPrima's* encoder to 56 or 64 kb/s (use the highest bit rate supported by all links), MPEG Layer II, Mono or G.722, M1. Select **Ind. Mono** for the line format.
- When entering the lines to use, remember that *CDQPrima* broadcasts to all lines. Continuing with our example, Select lines 1, 2 and 3 for left and 4, 5 and 6 for right. The English program will be sent on lines 1, 2 and 3, while the French program will be sent on lines 4, 5, and 6. In this example, english audio will be broadcast on lines 1, 2 and 3 while French audio is broadcast to lines 4, 5 and 6.

- **Set the decoder to Independent, 56 or 64 kb/s (the same as the encoder), mono, MPEG Layer II. To monitor the return audio from New York or Paris, select lines 1 or 4. You can monitor the return audio from London instead of New York by simply changing the decoder format to Line 2. If the return audio is using the G.722 algorithm, you can monitor New York and Paris simultaneously.**

Currently, Independent mono operation using MPEG Layer II is one-way, send audio only. Although you can monitor MPEG Layer II return audio from any location, only one location can be selected at a given time. Using G.722 as the return audio algorithm allows you to monitor return audio from two locations simultaneously.

3.5 Saving Your Custom Configuration

Once you are satisfied with your custom configuration, we recommend saving it as a Quick Configuration so that you can instantly reload it if you need it again. Just press the **SDSET** button, enter a descriptive name, and press **ENTER**. The **CDQPrima** will return an ID number that is used for reloading the configurations at any time.